

# **Thermomat**

Manual for Thermomat Controllers type T5002  
and Heating Pads HPA1400 and HPP900

## Equipment identification.



T5002 6 pin connector



5 pin to 6 pin connector for using new Heating Pads on older Control Units.



Simcal



Blue 5 pin Heating Pad



Black 5 pin Heating Pad with straps



A view of a Heating Pad with the cover removed to show the padding.  
Note the serial number on the cable.



A Mk2 Heating Pad element showing some of the wiring.  
Check wiring and copper strips for damage



A Mk3 Heating Pad element. Check copper strips are not damaged due to creasing and that all the wires are still attached.

The Heating Pads supplied new or as service exchanges all now have a 6 way connector. An adaptor cable from the 6 way connector to a 5 way connector as shown above is supplied when the returned Heating Pad has a 5 way connector. It is not possible to use the current Heating Pads with a control unit that has a 4 way connector without a modification to the control unit.

The screen wire on the cable to the Heating Pad is now taken via a separate pin on the 6 way connector. Previously the screen wire was taken via the metal shell of the 5 way connector.

## **IMPORTANT NOTICES**

The Thermomat **MUST** not be returned for repair without a certificate confirming the unit(s) has been decontaminated. **WHEN** this is not possible the nature of the contamination must be specified on the accompanying documentation which must be attached to the outside of the container. Please refer to the DHSS or CSA recommendations.

This unit should only be used with Heating Pads supplied by JMW Medical. Any Heating Pad already in your possession should be tested **BEFORE** it is connected to the control unit. Heating Pads should only be used with control units supplied by JMW Medical.

The control unit should be inspected to check for any damage prior to use. The control unit should not be used if any such damage is found. The Heating Pad should be inspected before use to check for any damage to the plug, internal wiring or external cable and the cover should be checked for any holes or piercing. If any such damage is found the Heating Pad should not be used.

Do not use the Heating Pad when folded. ALWAYS KEEP HEATING PAD FLAT.

Do not use the Heating Pad with the cable tucked-in.

This heating pad can be positioned under or over the patient.

Do not use pins or other metallic objects to fasten the Heating Pad. The electrical element will not be damaged by punctures from such objects, however, punctures in the Heating Pad outer sleeve can allow the ingress of liquids. (JMW Medical offers a recovering service for this occurrence).

Do not pull the Heating Pad by the electrical supply cable, or use the electrical supply cable as a "handle".

The control circuit of the Thermomat has been carefully designed with patient safety in mind. Separate sensors not only control the Heating Pad temperature, but also continuously monitor Heating Pad and patient temperature. Always ensure that the patient covers all of the sensors. The label on the Heating Pad indicates the sensor positions.

The Heating Pad may not achieve maximum temperature in free air due to heat being radiated to the surrounding air. A patient should therefore be present for correct operation. This point should also be considered for Heating Pad temperature checks and calibration. Testing and or calibration of the unit **MUST ONLY BE CARRIED OUT USING THE SIMCAL TEST JIG FOR THE CONTROL UNIT AND A SEPARATE SUITABLE TEST JIG FOR THE HEATING PAD.**

Do NOT store the Heating Pad below 10 degrees Celsius or the Heating Pad will need to be heated to 11 degree Celsius before operating with a control unit.

A cotton cover or draw sheet should be placed between the patient and the heating pad.

The heating pad can be gently curved.

The element and/or the internal wiring of this heating pad can be damaged if creased or folded.

Store the pad flat or use the loop provided to hang the pad up.

Check for damage from folding, creasing or sharp objects etc before use.

The patient must cover the sensors when the heating pad is in use.

See the label for recommended patient size.

Select the correct size of heating pad for the patient.

This heating pad may only be used with equipment manufactured by JMW Medical as detailed in the instruction manual.

Users should not use cleaning or decontamination methods different from those recommended by the manufacturer without first checking with the manufacturer that the proposed methods will not damage the equipment.

Do not place any object other than the patient on a sensor.

Care should be exercised to ensure potential equalisation (e.g. when used with HF surgical instruments or endocardial catheters)

The operator should consider if it is necessary to monitor the patient's temperature.

The operator should consider the implications of any other heating device in use.

Straps are provided to secure the heating pad if required.

An alarm will sound for 10 seconds if there is a mains failure and will continue if the mains is restored until the confirm button is pressed.

There are a number of alarms for over temperature and other faults these will only operate correctly if the Control Unit and Heating Pad are maintained and used as detailed in this manual

A fault in the Heating Pad can be indicated by intermittent alarming at the control unit.

The Control unit and Heating Pad should be inspected by a competent engineer for electrical safety and compliance to the full calibration procedure annually or immediately if dropped or damaged.

The equipment should not be used in the presence of mobile phones etc. The equipment complies with IEC 60601-1-2 (EMC.)

The equipment should not be disposed of without due care to the environment. Specialist advice should be sought from JMW Medical Ltd at the time of disposal.

Sharp objects can damage the cover and permit the ingress of fluids.

The operator should consider that although the pad is padded precautions should be take to check and prevent pressure sores.

The operator should consider that the use of materials with good thermal conductivity, such as water, gel and similar substances, with the heating device not switched on might decrease the temperature of the body of the patient.

The approximate time for the heating device to heat up from 20° to 37°C, when operated under conditions of adequate heat discharge is around 10 minutes.

The unit will automatically alarm when switched on and will not stop alarming until the confirm button is pressed. Do not press the confirm button until after the fault light, (RED), on the front panel comes on. This is to test that the alarm system is working.

When the unit is in a state of alarm after 10 seconds the independent safety device will switch over. This will be indicated by the fault light, (RED), illuminating.

**Do not test this unit without reading the manual. The T5002 cannot be tested without a SIMCAL calibration jig and a suitable test jig for the Heating Pad. MANY OF THE "SIMULATED TESTS" CAN PRODUCE TEMPERATURES AS MUCH AS 10 DEGREES DIFFERENT TO THE SELECTED TEMPERATURE.**

Due to the small sales volumes the neo-natal heated pad, HPN400, has not been tested to the current European standards and has not been produced from the first of January 2001.

The straps on the heating pad are designed to hold the heating pad on the table. When a patient is placed on the heating pad then the patient should be separately restrained.

**The system is can only fail safely if all the above instructions are adhered to and the equipment is calibrated and maintained as defined by the manufacturers. If in doubt how the Thermomat will react in any given circumstance contact the manufacturers.**

The Thermomat system is manufactured by:

**JMW Medical Ltd**  
Pentland Industrial Estate  
Loanhead  
Edinburgh  
Midlothian  
UK  
EH20 9QH

Telephone No. +44 131 448 0205  
Fax No. +44 131 448 0208  
WWW.jmw-group.co.uk

**PLEASE READ ALL SECTIONS CAREFULLY**

**Symbols used in this manual and on the product.**

1. Alternating current



2. Protective earth (ground)



3. Equipotentiality



4. Protection against the ingress of fluids IEC60529

**IPX0**

**IPX2**

5. Attention, consult ACCOMPANYING DOCUMENTS.



6. Off (power: disconnection from the mains)



7. On (power: connection to the mains)



8. Type BF Applied Part



9. Category AP Equipment



10. Conformity to the European Medical Device Directive 93/42/EEC as certified by Notified Body N. 0577



0577

11. Year of manufacture



12. Serial Number

SN

13. Catalogue number

REF

**INDEX**

|   |           |
|---|-----------|
| <b>1. TYPICAL (CURRENT) THERMOMAT SPECIFICATIONS</b>                    | <b>11</b> |
| 1.1. Control Unit   | 11        |
| 1.2. Heating Pad  | 12        |
| 1.3. Guidance and manufacture’s declaration – electromagnetic emissions | 13        |
| <b>DESIGN CONCEPT</b>   | <b>14</b> |
| <b>2. THERMOMAT APPLICATIONS.</b>                                       | <b>14</b> |
| <b>3. CONTROLLER DESIGN</b>   | <b>15</b> |
| <b>4. HEATING PAD DESIGN</b>  | <b>16</b> |
| <b>5. BLOCK DIAGRAM</b>   | <b>17</b> |
| <b>6. SUMMARY OF CONTROLS AND INDICATORS</b>                            | <b>17</b> |
| <b>7.1 INDICATORS:</b>  | <b>17</b> |
| 7.1.1 Power:  | 17        |
| 7.1.2 Heat  | 17        |
| 7.1.3 Fault:  | 17        |
| 7.1.4 Achieved Display:   | 17        |
| 7.1.5 Alarm Indicators  | 18        |
| <b>7.2 Controls</b>   | <b>18</b> |
| 7.2.1 Temperature Selector Switch:                                      | 18        |
| 7.2.2 Power Switch:   | 18        |
| 7.2.3 Confirm Button:   | 18        |
| <b>7. OPERATING INFORMATION</b>   | <b>18</b> |
| <b>8.1 Control Unit</b>   | <b>18</b> |
| <b>8.2 Heating Pad</b>  | <b>19</b> |
| <b>8.3 Operating Instructions</b>                                       | <b>20</b> |
| <b>8. CLEANING INFORMATION.</b>   | <b>21</b> |
| <b>9. CIRCUIT DESCRIPTION</b>   | <b>22</b> |
| <b>9.1. Main PCB Circuit Description.</b>                               | <b>22</b> |
| 9.1.1. Control Circuit (Sheet 2)  | 22        |
| 9.1.2. Alarm Circuit (Sheet 3)  | 22        |
| 9.1.3. Display Circuit (Sheet 4)  | 23        |
| 9.1.4. Power Supplies (Sheet 5)   | 23        |
| <b>9.2. Display PCB Circuit Description</b>                             | <b>24</b> |
| <b>9.3. Wiring.</b>   | <b>24</b> |

|       |   |    |
|-------|---|----|
| 9.4.  | Heating Pad Element & Wiring.               | 24 |
| 10.   | SERVICING AND CALIBRATION PROCEDURE.        | 25 |
| 10.1. | Control Unit Servicing and Calibration      | 25 |
| 10.2. | Heating Pad Servicing Information           | 25 |
| 10.3. | Servicing Intervals                         | 25 |
| 10.4. | Work Instructions                           | 25 |
| 12.   | TEST AND CALIBRATION PROCEDURES             | 26 |
| 12.1. | T5002 Test and Calibration (WI017)          | 26 |
| 12.2. | T5002 Test and Calibration Record           | 29 |
| 12.3. | Heating Pad Final Test (WI066)              | 30 |
| 12.4. | Heating Pad Final Test Record Sheet (CT006) | 31 |
| 12.5. | Heating Pad Inspection Record Sheet (CT009) | 32 |
| 13.   | MATERIALS LIST CONTROL UNIT                 | 33 |
| 14.   | MATERIALS LIST HEATING PAD                  | 37 |
| 14.   | CIRCUIT DIAGRAMS                            | 39 |

**1. TYPICAL (CURRENT) THERMOMAT SPECIFICATIONS**

**1.1. Control Unit**

The Thermomat T5002 control unit should not be used at less than the recommended distance from flammable gases, The equipment is not suitable for use in the presence of a flammable anaesthetic mixture with air or with oxygen or nitrous oxide.

|                                       |                                |
|---------------------------------------|--------------------------------|
| Classification:                       | Class I, Type BF Applied Part  |
| Protection against ingress of fluids: | IPX0                           |
| Conformity:                           | EN60601-1: 1990 & EN60601-2-35 |
| Mode of operation:                    | Continuous                     |
| Supply Voltage:                       | 230 Volts ac. 50/60Hz.         |

(The Thermomat can be supplied from the factory with the voltage range of 110Vac at frequencies of 50Hz. or 60Hz.)

|                             |                       |
|-----------------------------|-----------------------|
| Supply Current:             | 0.5A maximum.         |
| Output voltage:             | 24 Volts ac. 50/60Hz. |
| Output Fuse, (Front Panel): | F5A. 20mm.            |

(The output frequency is dependent upon the frequency of the supply voltage).

|                               |                                |
|-------------------------------|--------------------------------|
| Temperature Control Range:    | 33 to 40degree Celsius.        |
| Over Temperature cut-out:     | 41degree Celsius.              |
| Temperature Control Accuracy: | +/- 1.0 degree Celsius.        |
| Mains Input Fusing:           | T1.6A. 20mm, Live and Neutral. |
| Transformer output fusing     | F5A                            |

|         |       |
|---------|-------|
| Length: | 200mm |
| Width:  | 200mm |
| Height: | 105mm |

|         |                  |
|---------|------------------|
| Weight: | 2.5Kgms, approx. |
|---------|------------------|

|                       |  |
|-----------------------|--|
| Storage and handling: | The unit should be handled and stored in such a way as to prevent any damage. Store in a dry area. |
|-----------------------|--|

Environmental conditions for transport and storage

Temperature range –10 to +30 degrees Celsius  
 Humidity less than 90% non condensing  
 Pressure 500 to 1000 Hectare Pascal

## 1.2. Heating Pad

|                                       |  |                     |                                  |          |
|---------------------------------------|--|---------------------|----------------------------------|----------|
| Classification:                       | Category AP Equipment.                       |                     |                                  |          |
| Protection against ingress of fluids: | IPX2   |                     |                                  |          |
| Conformity:                           | EN60601-1: 1990 & EN60601-2-35               |                     |                                  |          |
| Mode of operation:                    | Continuous                                   |                     |                                  |          |
| Supply Voltage:                       | 24 Volts ac.                                 |                     |                                  |          |
| Thermistors                           | 25K ohms at 25 degrees Celsius (4 in series) |                     |                                  |          |
| Maximum Power:                        | 100 Watts                                    |                     |                                  |          |
| HPA1400                               | Adult:                                       | 140 x 53cms 2.0Kgms | DC. Resistance 7 Ohms +/-2 Ohms  | 82 Watts |
| HPP900                                | Paediatric:                                  | 90 x 53cms 1.5Kgms  | DC. Resistance 13 Ohms +/-5 Ohms | 45 Watts |

The above resistance measurements are taken at 25 degree Celsius.

|                          |  |
|--------------------------|--|
| Environmental conditions | Temperature range –10 to +30 degrees Celsius |
|                          | Humidity less than 90% non condensing        |
|                          | Pressure 500 to 1000 Hectare Pascal          |

This heating pad is classed as LOW HEAT TRANSFER

The unit should be tested to check the resistance values, above, are correct at the specified temperature.

**1.3. Guidance and manufacture’s declaration – electromagnetic emissions**

| <p>The Thermomat is intended for use in the electromagnetic environment specified below. The customer or user of the Thermomat should assure that it is used in such an environment.</p> |                   |   |
|--|-------------------|---|
| <b>Emissions Test</b>  | <b>Compliance</b> | <b>Electromagnetic environment - guidance</b>   |
| <p>RF emissions<br/>CISPR 11</p>   | <p>Group 1</p>    | <p>The Thermomat uses RF energy only for its internal function. Therefore, its RF emissions are very low and are not likely to cause any interference in nearby electronic equipment.</p>   |
| <p>RF emissions<br/>CISPR 11</p>   | <p>Class B</p>    | <p>The Thermomat is suitable for use in all establishments, including domestic establishments and those directly connected to the public low-voltage power supply network that supplies buildings used for domestic purposes.</p> |
| <p>Harmonic emissions<br/>IEC 61000-3-2</p>  | <p>Complies</p>   |   |
| <p>Voltage fluctuations/<br/>flicker emissions</p>   | <p>Complies</p>   |   |
| <p>RF emissions<br/>CISPR 11</p>   | <p>Complies</p>   | <p>The Thermomat is not suitable for interconnection with other equipment</p>   |

## **DESIGN CONCEPT**

The original concept of a safe electrically powered Patient Warming System arose as it was considered that an electronically controlled, low voltage Heating Pad would overcome some of the anomalies associated with conventional warming systems based on water filled Heating Pads. These water based warming systems have proved to be cumbersome in use, easily punctured, requiring regular replenishing to avoid opaqueness to "X-RAY", and the water can become contaminated if it is not changed regularly.

The domestic electric blanket, although in regular use, has been a contributory factor in numerous accidents. The proximity of mains electrical voltage to patients is not recommended. The standard electric blanket has also been known to create interference problems to monitoring equipment such as ECG. Etc.

To this end, the Thermomat system was designed, with the following requirements:

1. The electrical supply voltage to the warming Heating Pad had to be significantly lower than the minimum lethal surface electrocution voltage.
2. The maximum surface temperature that a correctly maintained Heating Pad could attain in the event of malfunction etc., should be no greater than 41 degrees Celsius, being the maximum temperature that the skin surface can tolerate without damage.
3. A design must be used such that in the event of malfunction, electrical power is disconnected from the Heating Pad, and both Audible and Visual alarms are activated.
4. Temperatures in the range 33 - 40 degrees Celsius should be selectable.
5. The electrical supply voltage to the Heating Pad should be electronically controlled, thereby ensuring transient free switching, and eliminating any possibility of "sparking" etc.
6. The Heating Pad must be lightweight, reasonably pliable in use, should offer a degree of patient comfort, be easily cleaned and disinfected.
7. The Controller and Heating Pad should be physically separated and both be portable, and easily stored. The Heating Pad being connected to the controller by means of an interconnecting cable that is attached at the controller by a "locking" type plug.
8. The control unit should not radiate spurious transients that could interfere with other equipment such as, Monitoring systems, cardiac pacemakers, etc.
9. The control unit should offer little or no susceptibility to surgical diathermy etc.
10. Visual display of the achieved Heating Pad temperature should be available.

## **2. THERMOMAT APPLICATIONS.**

The Thermomat Patient Warming system is becoming increasingly popular in a variety of areas.

Operating Theatre staff are finding the Thermomat far less cumbersome, and far more robust than traditional water Heating Pades, and of course, not having the leakage problems associated with water systems. The same is true for hot air systems.

The Thermomat can be used as an over or under Heating Pad.

The Adult Heating Pad is the most commonly used, however, surgical staff are using both the Adult Table and Paediatric Heating Pad, not only for these patients, but the Paediatric Heating Pad is used extensively for specific area warming of adult patients.

The largely "X-RAY" translucent nature of these Heating Pads has been of considerable benefit in the Operating Theatre.

There has also been a significant increase in ITU use. This follows the need for patient warming after long procedures. The traditional electric blanket is commonly used, but interference, and the worry of mains voltages, make the Thermomat ideally suited to this application.

The Thermomat Heating Pad is undoubtedly far more acceptable to patient comfort than other stiffer and less compliant electrical Heating Pads. Such Heating Pads have contributed to considerable problems associated with bed-sores etc. in the long term patient.

Hypothermia associated problems are increasing, and Thermomat provides the ideal warming system for these problems, as the patient feedback design proportionally reduces the heating. This feature allows for long-term patient warming starting at low temperatures. Thus Thermomat is appearing in large numbers in the Accident and Emergency, and Casualty areas.

In view of the largely "radiolucent" properties of the Heating Pad, it is also commonly used during procedures requiring image intensification and angiography where image latticing with conventional wire elements would create confusion of the X-Ray image.

Military hospital units, Oil-rigs etc., also find considerable applications for Thermomat, for exposure treatment etc.

### **3. CONTROLLER DESIGN**

The control unit of the Thermomat is housed in an industrial quality case. The case is fitted with a hook type handle for carrying, hooking onto a rail or positioning the unit at a desired viewing angle.

The front panel of the controller comprises of:

1. Three indicators, Power, Heat and Fault.
2. Temperature selector switch.
3. Heating Pad achieved temperature display.
4. Heating Pad locking connection socket.
5. Electrical output fuse.
6. Confirm push button.

The electronic control circuit of the T5002 controller has several alarm circuits.

An audible alarm is activated in the event of a malfunction associated with the temperature monitoring circuit, or the temperature control electronics, whether or not the malfunction leads to a temperature increase. This same audible alarm will be activated in the event of a temperature in excess of 41 degrees Celsius monitored at the Heating Pad element. The audible alarm is also activated when power is removed from the unit and continues to sound for 5 seconds. This provides protection should the power become disconnected by accident. These alarms are calibrated during test and if calibrated incorrectly may not operate as described above.

The audible alarm is also used to indicate that the temperature control switch has been changed and the user must confirm that the new selected temperature is correct.

In order to prevent continued use of the Thermomat system in the presence of an audible alarm, power is disconnected from the Heating Pad after approximately 15 seconds.

The rear panel of the T5002 controller houses the electrical supply switch, the electrical supply fuses and the necessary data covering electrical supply requirements, Model (REF) and Serial Numbers (SN). Etc.

#### **4. HEATING PAD DESIGN**

The Thermomat Heating Pad is designed around a linear element. Previous electrical Heating Pads, and some electrically heated Heating Pads currently available, are produced like their predecessors, around "wired" or "metal patterned" elements.

The linear element used in the Thermomat has no wire or tape lattices, and therefore offers significant resistance to fracture, and is largely "X-RAY" translucent (there is wiring and sensors at the periphery of the Heating Pad that are not X-RAY translucent. This does not cause a problem due to the large central translucent window).

The element is produced on a plastic laminate, which is totally enclosed within a high voltage and high temperature resistant sleeve.

Sixteen electrical sensors are positioned around the long sides of the Heating Pad in 8 pairs, their positions being staggered to ensure average thermal monitoring of the element.

All the electrical connections are firmly attached, and the cable ends are terminated at a suitable section of the Heating Pad. At this point, the electrical supply cable is firmly attached. The complete element is enclosed in medical grade polyester wadding. This wadding ensures even thermal transfer, and also greatly enhances patient comfort unlike some other flatter and stiffer Heating Pads that have been known to produce severe patient discomfort, and contributing to severe bedsores.

The entire Heating Pad is enclosed first in a polythene inner protective cover then an outer removable cover. The electrical supply and monitor cable exits the Heating Pad at one end. This cable is then terminated at the controller end, in a locking plug.

The outer cover can be removed for cleaning. The internal sheath is designed to protect the internal heating element and padding from contamination. This must not be damaged or removed or the warranty will be void. This additional internal sheath is fitted from serial number 98061190/5 onwards.

The covers are designed to meet IPX2, which does NOT mean that the complete Heating Pad is waterproof. Indeed if immersed for long period in body fluids the liquid will penetrate. The two-cover method is designed that should the outer cover become contaminated inside then it may be removed for cleaning (see Heating Pad Cleaning Information).

The materials used within the Heating Pad, and the mode of manufacture of the Heating Pad, allow it to be safely used (not the controller) in the presence of flammable gases, and Anaesthetic reagents.

5. **Block Diagram**

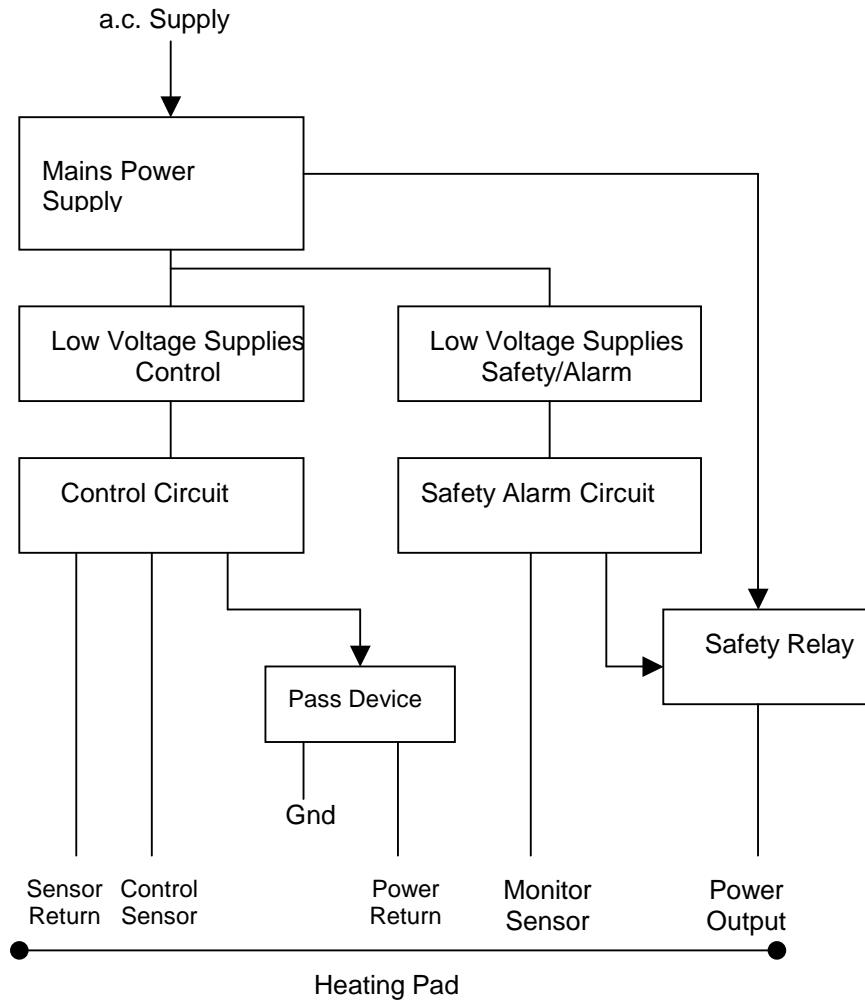

6. **SUMMARY OF CONTROLS AND INDICATORS**

7.1 INDICATORS:

7.1.1 **Power:**

This green indicator illuminates when electrical power is supplied to the control unit, and the rear panel electrical switch is ON. (marked | on the switch).

7.1.2 **Heat**

This amber indicator will illuminate whenever electrical low voltage is being supplied to the Heating Pad.

7.1.3 **Fault:**

This red indicator will illuminate if an audible alarm has occurred, which has been allowed to continue for in excess of 15 seconds. The electrical low voltage power to the Heating Pad is immediately terminated on operation of the Fault indicator.

7.1.4 **Achieved Display:**

This display indicates the current temperature of the Heating Pad.

### 7.1.5 Alarm Indicators

These provide an indication of possible fault conditions as follows. They are provided mainly for the use of service personnel.

| Alarm Indicator | Description  |
|-----------------|--|
| 1               | Control Sensor to Monitor Sensor difference > 3 degree Celsius |
| 2               | Monitor Sensor to Control Sensor difference > 3 degree Celsius |
| 3               | Control Sensor > 41 degree Celsius                             |
| 4               | Monitor Sensor > 41 degree Celsius                             |
| 5               | Temperature Control Switch (QR) > 41 degree Celsius            |
| 6               | Control Sensor (CS) < 10 degree Celsius or NO Heating Pad      |
| 7               | Monitor Sensor (MS) < 10 degree Celsius or NO Heating Pad      |
| 8               | Reference voltage < 7.5V                                       |
| 9               | Temperature has been changed but not confirmed                 |

> Means greater than

< Means less than

## 7.2 Controls

### 7.2.1 Temperature Selector Switch:

This control sets the required control temperature for the Heating Pad. It has marked settings in the range 33 to 40 degrees Celsius.

### 7.2.2 Power Switch:

This control is located on the rear panel of the T5002 controller, and as its name suggests, switches electrical power to the unit. It is marked | for ON and O for OFF.

### 7.2.3 Confirm Button:

This control is used by the user to confirm the Target temperature set on the rotary switch. This must be done within 15 seconds of the alarm sounding or power will be disconnected from the Heating Pad.

## 7. OPERATING INFORMATION

### 8.1 Control Unit

Unpack the T5002 control unit.

Carefully check for any signs of physical damage that may have resulted from carriage. The temperature selector switch should rotate freely on its axis, and should align with the relevant front panel markings.

Check the rating information on the rear panel of the control unit to ascertain that it is set correctly for the electrical mains supply to be used.

The controller is supplied with an IEC type 3 metre mains cable, which complies with the International Specification of Live: Brown, Neutral: Blue, Earth: Green/Yellow. A suitable 3 pin plug is moulded onto the cable and should be fused at 3 Amperes. The T5002 controller and Heating Pad should be operated from an earthed supply. The controller is shipped for use on a 230Volts ac. 50Hz. electrical supply.

## 8.2 Heating Pad

The Heating Pad should be unpacked, and the user should pay particular attention to the cautionary label affixed to the Heating Pad.

The Heating Pad consists of a linear element into which are mounted sixteen sensors. These sensors monitor and control the Heating Pad temperature. It is important that a patient is covering all of these sensors all the time. The sensors are staggered to aid this requirement.

### HPA1400 ADULT:

This Heating Pad is sized to fit the Theatre Operating table and is for use on adults. It is nominally 1400 mm x 530 mm.

### HPP900 PAEDIATRIC:

This Heating Pad is usually used with Paediatrics or when half tables are in use to heat the upper half of adults. It is nominally 900 mm x 530 mm.

The Heating Pad should be used with a cotton sheet placed between the Heating Pad and the patient. This cover can be omitted in the Operating Theatre when patients are transferred to the Operating Table complete with undercover.

All Heating Pads are fitted with a locking plug that connects the Heating Pad to the control unit at the socket on the controller front panel.

All Thermomat Heating Pads having plugs which have **BLUE or BLACK** covers can be used with Thermomat T1000, T2500, T3000, T3000E, T3000B, T5001, and T5002 controllers. Heating Pads with GREEN covers were only supplied for use with CREST or T2000 controllers with 4 Pin connectors. Heating Pads with RED covers are supplied for use only with conscious patients and have a 6 Pin connector.

### THE FOLLOWING NOTES APPLY TO THE HEATING PAD.

- 1 Do not use the Heating Pad when folded. ALWAYS KEEP HEATING PAD FLAT.
- 2 Do not use the Heating Pad with the cable tucked-in.
- 3 This heating pad can be positioned under or over the patient.
- 4 Do not use pins or other metallic objects to fasten the Heating Pad. The electrical element will not be damaged by punctures from such objects, however, punctures in the Heating Pad outer sleeve can allow the ingress of liquids. (JMW Medical offers a recovering service for this occurrence).
- 5 Do not pull the Heating Pad by the electrical supply cable, or use the electrical supply cable as a "handle".
- 6 The control circuit of the Thermomat has been carefully designed with patient safety in mind. Separate sensors not only control the Heating Pad temperature, but also continuously monitor Heating Pad and patient temperature. Always ensure that the patient covers all of the sensors. The label on the Heating Pad indicates the sensor positions.
- 7 The Heating Pad may not achieve maximum temperature in free air due to heat being radiated to the surrounding air. A patient should therefore be present for correct operation. This point should also be considered for Heating Pad temperature checks and calibration. Testing and or calibration of the unit MUST ONLY BE CARRIED OUT USING THE SIMCAL TEST JIG FOR THE CONTROL UNIT AND A SEPARATE SUITABLE TEST JIG FOR THE HEATING PAD.
- 8 Do NOT store the Heating Pad below 10 degrees Celsius or the Heating Pad will need to be heated to 11 degree Celsius before operating with a control unit.
- 9 A cotton cover or draw sheet should be placed between the patient and the heating pad.
- 10 The heating pad can be gently curved.
- 11 The element and/or the internal wiring of this heating pad can be damaged if creased or folded.
- 12 Store the pad flat or use the loop provided to hang the pad up.
- 13 Check for damage from folding, creasing or sharp objects etc before use.
- 14 The patient must cover the sensors when the heating pad is in use.
- 15 See the label for recommended patient size.
- 16 Select the correct size of heating pad for the patient.
- 17 This heating pad may only be used with equipment manufactured by JMW Medical as detailed in the instruction manual.

- 18 Users should not use cleaning or decontamination methods different from those recommended by the manufacturer without first checking with the manufacturer that the proposed methods will not damage the equipment.
- 19 Do not place any object other than the patient on a sensor.
- 20 Care should be exercised to ensure potential equalisation (e.g. when used with HF surgical instruments or endocardial catheters)
- 21 The operator should consider if it is necessary to monitor the patient's temperature.
- 22 The operator should consider the implications of any other heating device in use.
- 23 Straps are provided to secure the heating pad if required.
- 24 An alarm will sound for 10 seconds if there is a mains failure and will continue if the mains is restored until the confirm button is pressed.
- 25 There are a number of alarms for over temperature and other faults these will only operate correctly if the Control Unit and Heating Pad are maintained and used as detailed in this manual
- 26 A fault in the Heating Pad can be indicated by intermittent alarming at the control unit.
- 27 Sharp objects can damage the cover and permit the ingress of fluids.

### **8.3 Operating Instructions**

#### **Attention!**

**Although this Heating Pad is intrinsically safe - observe all principles of electrical safety and read the operating information.**

Lay the Heating Pad label uppermost on the surface on which it is to be used, Theatre table, Incubator tray, Bed, etc. The Heating Pad will remain in position and can be fixed using the straps provided. If additional strapping is required, any strapping, such as Foetal Monitor belts can be used. Position the Heating Pad such that the cable leaves the Heating Pad at a convenient point for connection to the control unit.

Position the T5002 control unit in a convenient location, or hang the unit on a convenient rail at a suitable distance from flammable gases.

Connect the cable from the Heating Pad to the front panel socket on the T5002 control unit. When firmly plugged in it will lock. The plug can be removed by depressing the small lever on the top of the plug whilst withdrawing the plug.

Connect the electrical supply plug to a suitable mains output socket.

Switch on the control unit by the rear panel switch.

The front panel Power indicator (green) will illuminate confirming that mains power is available. The front panel display, and possibly the Heat indicator, will also illuminate and the audible indicator will sound.

The Temperature selector knob should be positioned at the required temperature indicated on the front panel and the Confirm control pressed. At this point it is likely that the actual Heating Pad temperature, indicated in the Achieved display, is below the selected temperature. If this is the case, the Heat indicator (amber) will be constantly illuminated, indicating that electrical low voltage is being applied to the Heating Pad to raise its temperature to the setting of the Temperature selector switch.

This Heat indicator will remain illuminated, and the Achieved temperature display will increase, until the target temperature is approached. At this time the heat indicator will begin to flash periodically indicating that electrical power is being proportionally reduced as the required temperature is nearing.

When the required temperature is achieved, and displayed on the Achieved temperature display, the Heat indicator will flash indicating that power is being applied in bursts to maintain the Target temperature.

If the target temperature is again increased on the Temperature selector switch and the Confirm control pressed, the Heat indicator (amber) will again illuminate continuously until the new target temperature is approached and reached.

Conversely, if the Achieved temperature is above the target temperature, the Heat indicator (amber) will remain off until the Heating Pad temperature falls, and approaches the target temperature. The action of the Heat indicator will obviously be reflected by the Achieved temperature display.

If at any time the audible alarm sounds and does NOT clear by pressing the Confirm control the complete system should be referred to a technician for examination. Please take a note of the status of the alarm LED's on the rear panel. Please note calibration must only be undertaken using the prescribed SIMCAL Test Jig for the control unit and a suitable test jig for the Heating Pad.

Should the alarm sound and it cannot be cancelled by pressing the Confirm control then an indication of the possible fault will be displayed on the rear panel Alarm indicators. There are 9 indicators numbered 1 to 9 with the following functions.

| <u>Alarm Indicator</u> | <u>Description</u>   |
|------------------------|--|
| 1                      | Control Sensor to Monitor Sensor difference > 3 degree Celsius |
| 2                      | Monitor Sensor to Control Sensor difference > 3 degree Celsius |
| 3                      | Control Sensor > 41 degree Celsius                             |
| 4                      | Monitor Sensor > 41 degree Celsius                             |
| 5                      | Temperature Control Switch (QR) > 41 degree Celsius            |
| 6                      | Control Sensor (CS) < 10 degree Celsius or NO Heating Pad      |
| 7                      | Monitor Sensor (MS) < 10 degree Celsius or NO Heating Pad      |
| 8                      | Reference voltage < 7.5V                                       |
| 9                      | Temperature has been changed but not confirmed                 |

> Means greater than  
< Means less than

In the case of an alarm please note these indicators for engineers use. There are other faults, which may cause an alarm including but not limited to the failure of connections inside the Heating Pad.

*It should be noted that due to radiating heat to free air the Heating Pad will not necessarily attain temperature without a patient lying upon it.*

Following use of the system, the Heating Pad should be wiped clean, and/or disinfected. (See cleaning information).

For storage, the Heating Pad should be unplugged from the control unit, the cable tucked in the Heating Pad, and the Heating Pad kept flat or hung up using the loop provided.

Do not set the temperature above 39 degrees Celsius when perfusion through skin in contact with the Heating Pad is prejudiced.

When prolonged use with a cooled/unconscious (e.g. postoperative ICU's) patient is required, the normal medical precautions regarding temperature settings/differentials and monitoring should be observed.

## **8. CLEANING INFORMATION.**

Users should not use cleaning or decontamination methods different from those recommended by the manufacturer without first checking with the manufacturer that the proposed methods will not damage the equipment.

The Heating Pad and controller unit should be cleaned with soap and water, a mild detergent, or it may be disinfected and sterilised using sodium hypochlorite. Do NOT use BLEACH or PHENOLS.

The Heating Pad should NOT be autoclaved  
Do not immerse the Heating Pad.

The external cover may be removed if necessary for cleaning. An internal polythene cover is fitted to reduce the possibility of ingress of fluids.

Do not write on the Heating Pad with ink as this may damage the Heating Pad.

## 9. CIRCUIT DESCRIPTION

### 9.1. Main PCB Circuit Description.

Reference should be made to the circuit diagrams J115-70001 sheets 1 to 5. Sheet 1 is the top level showing the main functional blocks of the circuit.

#### 9.1.1. Control Circuit (Sheet 2)

##### 9.1.1.1. Control Loop

The main control loop consists of external thermistors connected to J2 which are biased by R83 and R82. R83 biases the Control Sensor (CS) and R82 biases the Monitor Sensor (MS). In all Heating Pad configurations the sensors are 20k ohms at 25 degree Celsius.

J115-70001 sheet 2 shows the control circuitry. The Control Sensor (CS) signal is filtered and then buffered by U3B before being used by the proportional temperature controller U1 at pin 6. This IC compares the voltage from the control sensors with the voltage from the front panel switch on pin 9. The Q out on pin 3 produces pulses to fire the TRIAC Q1. The power to the Heating Pad is varied from continuous, pulses every half cycle, to low power, one pulse per second giving one half cycle out of every 50 cycles of the mains supply.

U1 provides an external reference voltage VZ that is set to 7.5V by R19 and then buffered by U3A before being used to provide the bias for the thermistors through R82 and R83. This reference is also used to bias the temperature control switch. R12 and R14 set the lower and higher temperature settings of 33 and 40 degree Celsius. U1 has a zero crossing detector using pin 10 as input and a 1 second ramp generator set by C3. Maladjustment can have an adverse effect on safety.

The voltage from the temperature control switch arrives at U1 pin 9. This signal is linear to temperature setting, but to enable the internal control system U1 to function with NTC thermistors this signal is made non-linear and compatible with the NTC thermistors. The modified control signal QR is available at U1 pin 8 and is used by the Alarm circuitry.

##### 9.1.1.2. Front Panel LED's

There are three LED's, Fault, Heat and Power. The Power LED is driven by the +12VC supply and as such is illuminated whenever the unit is connected to the mains a.c. supply.

The Heat LED is connected across the Heating Pad output and as such is illuminated whenever power is being supplied to the Heating Pad, pulsed or continuous.

The Fault LED is only illuminated when the internal relay RLY1 is NOT actuated i.e. when power has been removed from the Heating Pad due to not confirming a change in temperature set by the temperature control switch or an alarm condition.

#### 9.1.2. Alarm Circuit (Sheet 3)

There are 9 possible sources of alarm, which will cause the sounder to activate followed 15 seconds later by disconnection of the power to the Heating Pad by RLY1. They are divided into the following groups. All signals are buffered before being used the CS by U10A, the MS by U10B and QR by U10D. The CS and MS signals are also filtered to stop any noise from the Heating Pad causing damage to the buffer IC's. The 9 alarm signals are displayed on the rear panel using LED's. The signal buffering is such that noise will be rejected but intermittent breakage of wires in a Heating Pad may well show up with a low or intermittent sounding alarm.

| <u>LED</u> | <u>Description</u>       | <u>Diode</u> |
|------------|--------------------------|--------------|
| 1          | CS-MS > 3 degree Celsius | D41          |
| 2          | MS-CS > 3 degree Celsius | D40          |
| 3          | CS > T max               | D39          |
| 4          | MS > T max               | D38          |
| 5          | QR > T max               | D37          |
| 6          | CS < 10 degree Celsius   | D36          |
| 7          | MS < 10 degree Celsius   | D35          |

|   |                     |     |
|---|---------------------|-----|
| 8 | V ref < 7.5V        | D34 |
| 9 | Changed Temperature | D33 |

> Means greater than  
< Means less than

#### 9.1.2.1. Control and Monitor >3 degree difference

The buffered CS and MS signals are subtracted from each other and amplified by 10 by U10C to produce a +/- 2.5V signal if the difference is greater than 3 degree Celsius. Comparator U9B and U9C generate an alarm at TP8 and TP9 should the difference in temperature be greater than 3 degree Celsius in either direction.

#### 9.1.2.2. Control, Monitor and QR >41 degree Celsius

The buffered CS, MS and QR signals are compared with a voltage equivalent to 41 degree Celsius by U8D, U9A and U8C to produce alarm signals on TP10, TP11 and TP12 should any of them be greater than 41 degree Celsius.

#### 9.1.2.3. Control and Monitor < 10 degree Celsius

The buffered CS and MS signals are compared with a voltage equivalent to 10 degree Celsius by U8B and U6D to produce an alarm signal on TP13 and TP14 should either be less than 10 degree Celsius.

#### 9.1.2.4. V Reference < 7.5V

The +VZ reference voltage used in the control loop is compared with a secondary reference voltage and should it be less than 7.5V an alarm is generated at TP7.

#### 9.1.2.5. Temperature Switch Changed

When the position of the temperature switch is changed the signal CHANGET goes high (+12V) and this is detected by U6C to give an alarm on TP17.

#### 9.1.2.6. Alarm Sounder

All the 9 alarm outputs are OR'ed together using D17 to 25. Should any of the 9 alarms be active the output of the associated comparator will be low -12V and will pull down the gate of T2 so switching it off. This in turn switches T3 ON so enabling U7 to pulse the sounder On/Off. Should power be removed from the unit C18 stores enough power to keep the sounder going for up to 10 seconds.

When any of the alarms has been active for more than 15 seconds, the signal is delayed by U6A and B, the relay (RLY1) controlling power to the Heating Pad is disabled so removing power from the Heating Pad.

### 9.1.3. Display Circuit (Sheet 4)

The display consists of a 3-digit LED seven segment display. This is driven by U4, which has an internal ADC. The ADC converts the voltage on pin 31 using a reference voltage from D10. The full scale is 999mV corresponding to 99.9 degree Celsius on the display. Normal operating range is 33 to 40 degree Celsius i.e. 330 to 400mV.

#### 9.1.3.1. Signal Conditioning

This is performed by U5A which linearises, inverts and conditions the signal from CS-B. R33 presets the offset and R41 sets the gain of this circuit. Typical values are 0.687V offset and 0.135 gain.

#### 9.1.3.2. ADC

U4 contains an ADC and LED drivers this ADC requires a reference voltage of 1.00V, which is provided by D10 and set by R38.

### 9.1.4. Power Supplies (Sheet 5)

There are two separate sets of power supplies. One supply for the control loop circuitry and the second supply for the alarm circuitry. This is to ensure that one supply cannot interfere with the other and so produce faults, which do not exist, and more importantly the system will not fail to report faults should they exist.

#### 9.1.4.1. Control Supplies

Two regulators U13 and U12 produce plus and minus 12 volts for the control circuitry.

#### 9.1.4.2. Alarm Supplies

Three regulators U11, U14 and U15 produce +5V and +/-12V for the alarm and display circuitry.

### 9.2. Display PCB Circuit Description

The circuit is contained on J115-70002 and consists of three LED's LED1, 2 and 3, a 9 position rotary switch to set the temperature and a push button switch for Confirm. All connections to the main PCB are through J1 a 2 x 18-way connector.

### 9.3. Wiring.

The a.c. supply 230 enters the unit via a filtered connector, which meets the requirements of medical products regarding leakage current. The line and neutral are independently fused at 1.6A, before entering the ON/OFF switch which controls the power to the transformer that produces 24V a.c. and 12V a.c. The Transformer has primary taps allowing it to be set for 230V a.c. or 110V a.c. The standard setting is 230V a.c.

The output of the transformer is inline fused before the connections to the Main PCB using a 4 way Pheonix MC1.5 series connector J4.

The output connector to the Heating Pad on the front panel is a 6 way socket. This is connected to the Main PCB via two connectors J1 and J2. J1 is the power and J2 is the sensor connections from the Monitor and Control loops. The earth screen is connected to the remaining pin of the 6 way connector.

The front panel mounted output fuse is connected to the Main PCB via. J5. This protects the output against short circuits.

All connections between the two PCB's are via. J3 on the Main PCB.

### 9.4. Heating Pad Element & Wiring.

The element and associated wiring is detailed in the block diagram. No separate wiring diagram is provided.

## **10. Servicing and Calibration Procedure.**

### **10.1. Control Unit Servicing and Calibration**

It is not possible to calibrate a T5002 control unit without a SIMCAL test jig. Normally electrical safety checks can be performed without a SIMCAL. The SIMCAL does not test or calibrate the Heating Pad which requires additional equipment.

### **10.2. Heating Pad Servicing Information**

The Heating Pad may be come contaminated to such an extent that the outer cover needs cleaned. The outer cover may be removed. Once removed the cover may be cleaned by use of warm water and neutral detergent or in heavily soiled cases with the use of sodium hypochlorite diluted to the appropriate concentration. DO NOT BLEACH or use PHENOLS. For Heating Pads with serial number 98061190/5 or later an additional inner protective cover is fitted designed to protect the internal heating elements and padding from contamination. This must not be removed or damaged in any way or the warranty will be void. The tape used to secure this inner cover is NOT standard 'sellotape' due to the environmental conditions the Heating Pad has to withstand. Do not remove or replace this tape. It is not recommended that any other repairs are performed. See 11.4

The elements, internal cabling, external cabling, connections and sensors (thermistors) should be tested to the details provided in the specifications section as detailed in the Heating Pad Inspection Test Sheet contained at the end of this manual.. The normal electrical safety checks should also be completed.

### **10.3. Servicing Intervals**

Both the T5002 and the Heating Pad should be serviced at not more than 12 monthly intervals and in the event of hard or misuse immediately. It is preferable to check the Heating Pad more regularly for damage since misuse is less obvious. Close inspection of the Heating Pad using x-rays may prove a suitable means of inspection for damage or broken wires without dismantling the Heating Pad. See 11.4

### **10.4. Work Instructions**

The following work instructions are a *sample* of those used in the factory. These instructions are not comprehensive and are for use only by a trained operative along with other documentation and assume "good working practices" are followed. In particular the Heating Pad work instructions may appear simple but requires the Heating Pad to be fully dismantled and each individual item inspected. Only personnel who are trained in how to inspect the Heating Pad and have the correct environment available should carry out this procedure. Some of the procedures are classed as manufacturing and require the service organisation to comply with various sections of the Medical Devices Directive.

12. **TEST AND CALIBRATION PROCEDURES**

12.1. **T5002 Test and Calibration (WI017)**

1 **PURPOSE**

1.1 The purpose of this Work Instruction is to detail the steps, which must be taken to complete the Controller calibration and test. **Any error allowed in this procedure will seriously affect the temperature the Heating Pad achieves and the alarm systems validity.**

2 **REFERENCES**

2.1 QP 031 - Non Conforming items  
CT 002 - Test results sheet

3 **INSTRUCTIONS**

3.1 Non conforming items are to be handled as detailed in QP 031 - Non conforming item procedure.

3.2 The technical drawings give all details of construction, including wire lengths and colours and should be followed closely.

3.3 The results from the following tests should be recorded on test results sheet CT 002.

4 **TEST EQUIPMENT**

Test jig SIMCAL s/n SIM1  
Transformer s/n TJP002  
Digital Voltmeter  
Variac  
Trailing Lead  
Fully Shielded Adapter to Voltmeter.  
Noise meter

4.1 **CALIBRATION**

Connect the Front Panel Assembly to the Main PCB Assembly and then connect the Transformer Assembly, TJP002, to the Main PCB. Test Jig SIMCAL, SIM1, should be connected to the front panel 6 way connector. Set SIMCAL to 33 deg C. Measure the voltage at the following points with reference to TP24.

|       | <u>Location</u> | <u>Result</u> | <u>Tolerance</u> |
|-------|-----------------|---------------|------------------|
| 4.1.1 | TP18            | +15Volts      | 14.25 to 15.75   |
| 4.1.2 | TP22            | -12Volts      | -11.40 to -12.60 |
| 4.1.3 | TP19            | +12Volts      | 11.40 to 12.60   |

- 4.1.4 TP20 -12Volts -11.40 to -12.60
- 4.1.5 TP21 +5.0Volts 4.75 to 5.25
- 4.1.6 TP23 +1.23Volts 1.20 to 1.30
- 4.1.7 TP27 +7.50Volts Set R43 for 7.49 to 7.51
- 4.1.8 TP26 -7.50Volts -7.47 to -7.53
- 4.1.9 TP1 +7.50Volts Set R19 for 7.49 to 7.51
- 4.2 Set Test Jig to 33 deg C and Front Panel to 33 deg C then adjust R12 for flashing HEAT LED. The ON time should be set for 10 to 15% using meter on test jig. Set Test Jig to 40 deg C and Front Panel to 40 deg C and adjust R14 for flashing HEAT LED. The On time should be set for 15 to 20% using meter on test jig. The 33 setting may require adjustment after setting 40. This should be repeated at both 33 and 40 until the required ON time is achieved at both 33 and 40. Check that the unit produces flashing HEAT LED at all other settings of temperature.
  - 4.2.1 Set R55 for alarm on 41 deg C.  
Set switch to 40.75 and adjust R55 so LEDs 3 & 4 just come on.  
Set switch to 40.5 and press reset. All alarms should be off.  
Take reading of TP6 2.71 to 2.74 volts
  - 4.2.2 U4 Pin 26 -5.0Volts 4.75 to 5.25
  - 4.2.3 U4 Pins 35 to 36. Set R38 for 0.998 to 1.002 Volts.
  - 4.2.4 TP2 0.687Volts Set R33 for 0.686 to 0.688.
  - 4.2.5 Set Test Jig to 33 deg C then adjust R41 for 32.9 to 33.1 displayed on front panel display. Set Test Jig to 40 deg C and check that display now shows between 39.9 and 40.1.

## 5 ALARMS

The unit is now checked for all Alarm conditions. The rear panel has 9 LED's, which provide indication as to which alarm has been activated. As each test is performed the alarm condition should be left for 15 seconds at which time the ALARM LED on the front panel should illuminate and the relay should disconnect power from the Test Jig.

| <u>Alarm LED</u> | <u>Description</u>  | <u>Diode</u> |
|------------------|---------------------|--------------|
| 1                | CS-MS > 3 deg C     | D41          |
| 2                | MS-CS > 3 deg C     | D40          |
| 3                | CS > T max          | D39          |
| 4                | MS > T max          | D38          |
| 5                | QR > T max          | D37          |
| 6                | CS < 10 deg C       | D36          |
| 7                | MS < 10 deg C       | D35          |
| 8                | V ref < 7.5V        | D34          |
| 9                | Changed Temperature | D33          |

- 5.1 Set Test Jig to 36/39. LED 1.
- 5.2 Set Test Jig to 39/36. LED 2.
- 5.3 Set Test Jig to CS 41 MS39. LED 3.
- 5.4 Set Test Jig to MS 39 MS 41 LED 4.
- 5.5 Set Test Jig to CS o.c. LED 6.
- 5.6 Set Test Jig to MS o.c. LED 7.

Change the temperature set switch. LED 9 should illuminate and cancel when CONFIRM is pressed.

Warning. This test uses 230v. Observe safety precautions. Plug the trailing lead into the Variac and connect the Transformer TJP002 and the fully shielded adapter to the trailing lead. Plug the adapter into the voltmeter and switch on. Turn the Variac until you get a setting of 199vAC. Check that the T5002 has not changed temperature on the display and that the results from tests 4.1.1 to 4.1.9 are unaffected.

## 6 Alarm Level

Check the alarm noise level is greater than 65 dB at 1 metre.

12.2. T5002 Test and Calibration Record

Unit Serial Number: \_\_\_\_\_ Tested By: \_\_\_\_\_  
 PCB Serial No. \_\_\_\_\_ Transformer No. \_\_\_\_\_ Date \_\_\_\_\_

Results

| Test No | TP No           | Range                                   | Result | Pass |
|---------|-----------------|---|--------|------|
| 4.1.1   | TP 18           | +14.25 to +15.75 volts dc               |        |      |
| 4.1.2   | TP 22           | -11.4 to -12.6 volts dc                 |        |      |
| 4.1.3   | TP 19           | +11.4 to +12.6 volts dc                 |        |      |
| 4.1.4   | TP 20           | -11.4 to 12.6 volts dc                  |        |      |
| 4.1.5   | TP 21           | +4.75 to 5.25 volts dc                  |        |      |
| 4.1.6   | TP 23           | +1.23 to +1.3 volts dc                  |        |      |
| 4.1.7   | TP 27           | Set R43 +7.49 to +7.51 volts dc         |        |      |
| 4.1.8   | TP 26           | -7.47 to -7.53 volts dc                 |        |      |
| 4.1.9   | TP 1            | Set R19 +7.49 to +7.51 volts dc         |        |      |
| 4.2     |                 | Set R12 for 33 Deg C & R14 for 40 Deg C |        |      |
| 4.2.1   | TP 6            | Set R55 for 41 Deg C alarm              |        |      |
| 4.2.2   | U4 Pin 26       | -4.75 to -5.25 volts dc                 |        |      |
| 4.2.3   | U4 pin 35 to 36 | 0.999 to 1.001 volts dc                 |        |      |
| 4.2.4   | TP 2            | Set R33 to 0.687                        |        |      |
| 4.2.5   |                 | R41 for 33 Deg C                        |        |      |
| 5.1     |                 | Jig Set 36/39 LED1                      |        |      |
| 5.2     |                 | Jig Set 39/36 LED2                      |        |      |
| 5.3     |                 | Jig Set CS43 LED3                       |        |      |
| 5.4     |                 | Jig Set MS43 LED4                       |        |      |
| 5.5     |                 | Jig Set CS O/C LED6                     |        |      |
| 5.6     |                 | Jig Set MS O/C LED7                     |        |      |
| 5.7     |                 | Move Temp SW LED9                       |        |      |
| 5.8     |                 | 240 volts ac to 199 volts ac            |        |      |
| 6       |                 | Alarm Noise level >65dB                 |        |      |

Serial Numbers of Test Equipment used

Test jig SIMCAL s/n SIM1 \_\_\_\_\_  
 Transformer s/n TJP002 \_\_\_\_\_  
 Digital Voltmeter \_\_\_\_\_  
 Variac \_\_\_\_\_  
 Trailing Lead \_\_\_\_\_  
 Fully Shielded Adapter to Voltmeter. \_\_\_\_\_  
 Noise meter \_\_\_\_\_

### **12.3. Heating Pad Final Test (WI066)**

#### **PURPOSE**

The purpose of this Work Instruction is to detail the steps, which must be taken to complete the Heating Pad resistance checks

#### **REFERENCES**

QP 31 - Non Conforming items  
CT 006 - Test results sheet

#### **INSTRUCTIONS**

Non conforming items are to be handled as detailed in QP 031 - Non-conforming item procedure.

The results from the following work instructions should be recorded on test results sheet CT 006.

- a. Place the Heating Pad in the test area and connect the Heating Pad test jig to it.
- b. Set the digital meter to the OHMS range and measure the resistance between pins 1 and 5 (the two red test points on the test jig). Record the value on test sheet CT006 ensuring that the values are in range measure the resistance between pins two to three and pins three to four and record the values on the test sheet.
- c. Connect the Test Resistor to the Test Jig and ensure the display shows the same value when switched between Monitor and Control sensors. Connect the Heating Pad and allow the set temperature of 40 degrees to be achieved. Switch between Monitor and Control sensors noting the readings. Leave on soak test for 24 hours and repeat.

#### **TEST EQUIPMENT**

Digital Multimeter  
Heating Pad test jig block  
Test Jig T5002  
Test Resistor

**12.4. Heating Pad Final Test Record Sheet (CT006)**

Heating Pad Serial Number: \_\_\_\_\_

Tested By: \_\_\_\_\_ Date: \_\_\_\_\_

Ambient temperature during test must be between 18 and 29 degrees

1. MEASUREMENTS TAKEN from pin 1 to pin 5.

| <u>HEATING PAD TYPE</u> | <u>VALUE</u> | <u>TEST STANDARD</u>   | <u>REPAIR VALUE</u> |
|-------------------------|--------------|------------------------|---------------------|
| <u>HPA (FULL TABLE)</u> | _____        | <u>6 TO 14 Ohms</u>    | _____               |
| <u>HPP (HALF TABLE)</u> | _____        | <u>10 TO 14 Ohms</u>   | _____               |
| <u>HPN (NEO-NATAL)</u>  | _____        | <u>30 TO 35 Ohms</u>   | _____               |
| <u>OTHER</u>            | _____        | <u>TO BE SPECIFIED</u> | _____               |

**SENSOR MEASUREMENT**

Monitor Sensor Resistance (Pin 2 to 3) 17 TO 25kO \_\_\_\_\_

Control Sensor Resistance (Pin 3 to 4) 17 to 25kO \_\_\_\_\_

2. Test Heating Pad on test jig. At 39 °C the difference between the monitor and control must be less than 1 °C.

Monitor Circuit Temp: - \_\_\_\_\_ then \_\_\_\_\_

Control Circuit Temp: - \_\_\_\_\_ then \_\_\_\_\_

3. Calibrated Test Equipment used

- Digital Multimeter S/No \_\_\_\_\_
- Heating Pad test jig block S/No \_\_\_\_\_
- Test Jig T5002 S/No \_\_\_\_\_
- Test Resistor S/No \_\_\_\_\_

4. Ambient Temperature at time of test \_\_\_\_\_

**12.5. Heating Pad Inspection Record Sheet (CT009)**

HEATING PAD SERIAL No: \_\_\_\_\_ TESTED BY: \_\_\_\_\_  
 HOSPITAL NAME: \_\_\_\_\_ DATE: \_\_\_\_\_

EXTERNAL VISUAL INSPECTION REPORT

---



---



---



---

MEASUREMENTS TAKEN

| <u>HEATING PAD TYPE</u> | <u>VALUE</u> | <u>TEST STANDARD</u>   | <u>REPAIR VALUE</u> |
|-------------------------|--------------|------------------------|---------------------|
| <u>HPA (FULL TABLE)</u> | _____        | <u>6 TO 14 Ohms</u>    | _____               |
| <u>HPP (HALF TABLE)</u> | _____        | <u>10 TO 14 Ohms</u>   | _____               |
| <u>HPN (NEO-NATAL)</u>  | _____        | <u>30 TO 35 Ohms</u>   | _____               |
| <u>OTHER</u>            | _____        | <u>TO BE SPECIFIED</u> | _____               |

**SENSOR MEASUREMENT**

Monitor Sensor Resistance (Pin 2 to 3) 17 TO 25kO \_\_\_\_\_

Control Sensor Resistance (Pin 3 to 4) 17 to 25kO \_\_\_\_\_

Earth (pin 6 to braid in Heating Pad) \_\_\_\_\_

INTERNAL INSPECTION REPORT (Remove cover and dismantle Heating Pad)

---



---



---



---

**WORK REQUIRED**

|                  |        |                     |        |
|------------------|--------|---------------------|--------|
| REPLACE COVER    | YES/NO | REPLACE PLUG        | YES/NO |
| REPLACE ELEMENTS | YES/No | REPLACE WADDING     | YES/NO |
| REPLACE CABLE    | YES/NO | REPLACE THERMISTORS | YES/NO |
| UPGRADE WIRING   | YES/NO | FIT 6 PIN PLUG      | YES/NO |

**13. Materials List Control Unit**

| J115-00001 T5002 Thermomat Controller 1 |                              |              |     |                    |               |           |
|---|------------------------------|--------------|-----|--------------------|---------------|-----------|
| ITEM                                    | DESCRIPTION                  | JMW Part No. | Qty | Manufacturer       | Supplier      | Part No.  |
|   | Handle Rod                   | J115-20001   | 1   |                    |               |           |
|   | Handle Hook                  | J115-20002   | 1   |                    |               |           |
|   | Handle Bush                  | J115-20003   | 1   |                    |               |           |
|   | Case Assembly                | J115-60001   | 1   | Schroff            |               |           |
|   | Front Panel Assembly         | J115-60002   | 1   |                    |               |           |
|   | Rear Panel Assembly          | J115-60003   | 1   |                    |               |           |
|   | Main PCB                     | J115-70001   | 1   |                    |               |           |
|   | Transformer Assembly         | J115-60004   | 1   |                    |               |           |
|   | Penny Washer                 | 312-00001    | 1   |                    |               |           |
|   | Black Heatshrink             | 323-0014     | 1   |                    | Farnell       | 107-448   |
| J115-60002 Front Panel Assembly 1       |                              |              |     |                    |               |           |
| ITEM                                    | DESCRIPTION                  | JMW Part No. | Qty | Manufacturer       | Supplier      | Part No.  |
|   | Front Panel                  | J115-10001   | 1   | Schroff            |               |           |
|   | Front Panel Overlay          | J115-40001   | 1   | Touch Panels       |               |           |
|   | Display PCB Assembly         | J115-70002   | 1   |                    |               |           |
|   | Conn 6 way AXR socket        | 350-0008     | 1   |                    | RS Components | 449-231   |
|   | Fuseholder                   | 300-0001     | 1   | Bulgin F357        | Farnell       | F357      |
|   | Fuse Link F5A                | 301-0000     | 1   | Beswick TDS500     | Farnell       | 151-495   |
|   | Knob 21mm 6mm shaft          | 337-0004     | 1   | Bulgin             |               | KX2621603 |
|   | Cap 21mm                     | 337-0000     | 1   | Bulgin             |               | KX3021103 |
|   | Dial with arrow 21mm         | 337-0002     | 1   | Bulgin             |               | KX4521113 |
|   | Locking device 6mm           | 337-0006     | 1   | Bulgin             |               | KX4915600 |
|   | Dress nut and cap            | 341-0006     | 1   | C and K            | Phoenix Elec. | 8025      |
|   | Conn 2 way Plug Free         | 356-0130     | 1   | IMO 21.1550/2      | Farnell       | 304-4592  |
|   | Conn 3 way Plug Free         | 356-0131     | 1   | IMO 21.1550/3      | Farnell       | 304-4609  |
|   | Conn 6 way housing 0.1       | 356-0008     | 1   | Molex              | Farnell       | 143-189   |
|   | Crimp Terminal 0.156         | 356-0025     | 5   | Molex              | Farnell       | 143-198   |
|   | Crimp Terminal 0.1           | 356-0024     | 3   | Molex              | Farnell       | 143-201   |
|   | Crimp Ring Red M3            | 359-0016     | 1   | Davco              | Farnell       | 150-268   |
|   | M3 x 10mm c/sk screw         | 310-0012     | 1   | Serco Ryan         | Farnell       | 149-641   |
|   | M3 internal tooth washer     | 312-0003     | 1   | Serco Ryan         |               |           |
|   | M3 Full Nut                  | 311-0002     | 1   | Serco Ryan         |               |           |
|   | Wire 18AWG 16/30             | 322-0061     | a/r |                    | Farnell       | 436-380   |
|   | Wire 16/0.2 Orange UL1061    | 322-0007     | a/r |                    | Farnell       | 140-342   |
|   | Wire 16/0.2 Yellow U11061    | 322-0008     | a/r |                    | Farnell       | 140-343   |
|   | Wire 7/0.2 Green UL1061      | 322-0039     | a/r |                    | Farnell       | 140-316   |
|   | Wire 7/0.2 Blue UL1061       | 322-0038     | a/r |                    | Farnell       | 140-317   |
|   | Wire 7/0.2 Purple UL1061     | 322-0043     | a/r |                    | Farnell       | 140-318   |
|   | EMC Shielding Tape           | 901-0002     |     |                    | Farnell       | 187-860   |
| J115-60003 Rear Panel Assembly 1        |                              |              |     |                    |               |           |
| ITEM                                    | DESCRIPTION                  | JMW Part No. | Qty | Manufacturer       | Supplier      | Part No.  |
|   | Rear Panel                   | J115-10002   | 1   | Phoenix Precision  |               |           |
|   | Fuseholder                   | 300-0001     | 1   | Bulgin F357        | Farnell       | F357      |
|   | Switch DPST Green 0/1        | 344-0000     | 1   | RS                 | 664-553       |           |
|   | Inlet Filter                 | 304-0000     | 1   | Bulgin PS0621/6amp | ESD           | 011498X   |
|   | Female 0.187 Faston          | 359-0020     | 2   | RS                 | 433-107       |           |
|   | Fuse Link T1A                | 301-0001     | 2   | Beswick TDS506     | Farnell       | 151-521   |
|   | Fuseholder                   | 300-0001     | 1   | Bulgin F357        | Farnell       | F357      |
|   | Ring 4mm Red                 | 359-0017     | 1   | Davico             | Farnell       | 150-270   |
|   | Wire 7/32 Brown UL1015       |              | a/r | ESD                |               | 046277D   |
|   | Wire 7/32 Blue UL1015        |              | a/r | ESD                |               | 046276F   |
|   | Wire 32/0.2 Grn/Ylw DEF61-12 |              | a/r | ESD                |               | 071842F   |
|   | Earth Pin                    | 356-0030     | 1   | Multi-contact      |               | 04.0057   |
|   | M6 Crinkle Washer            | 356-0033     | 2   | Multi-contact      |               | 08.0704   |
|   | M6 Chamfer Washer            |              | 2   | Multi-contact      |               | 08.0601   |
|   | M6 Nut                       | 356-0032     | 3   | Multi-contact      |               | 08.0501   |
|   | M3 x 10 Pozi CSK Head        | 310-0006     | 2   |                    |               |           |

*Thermomat Manual*

|                            |          |     |        |         |         |  |
|----------------------------|----------|-----|--------|---------|---------|--|
| M3 Shk Prf washer          | 312-0003 | 2   |        |         |         |  |
| M3 Full Nut                | 311-0002 | 2   |        |         |         |  |
| Ring 6mm Blue              | 359-0015 | 1   | Davico | Farnell | 150-277 |  |
| PVC Insulation Boot Black  | 304-0007 | 1   |        | Farnell |         |  |
| Braided Sleeving           | 323-0024 | a/r |        |         |         |  |
| Black Shrinkable Sleeving  | 323-0014 | a/r |        |         |         |  |
| Green / Yellow 18AWG 16/30 | 322-0061 | a/r |        | Farnell | 436-380 |  |

| J115-70001  | Main PCB               |              | 1   |                      |          |            |
|---|------------------------|--------------|-----|----------------------|----------|------------|
| ITEM  | DESCRIPTION            | JMW Part No. | QTY | Manufacturer         | Supplier | Part No.   |
|   | Bare PCB               | J115-30001   | 1   | Strathclyde Circuits |          |            |
| D4, 5,6,7,8,9<br>11,12,13,14,<br>15,16,17,18,<br>19,20,21,22,<br>23,24,25,32.                               | Diode 1N4148           | 250-0001     | 22  |                      | Farnell  | 1N4141     |
| D26, 27,28,29,30  | Diode 1N4007           | 251-0000     | 5   | Farnell              | 1N4007   |            |
| R20, 27,28,29,<br>30,35,39,47,<br>51,52,53,65,<br>68,71,74,75,<br>76,77,79,80,<br>81,86,87,88,<br>89,90,91. | Resistor 10k 0.25W 1%  | 100-0038     | 27  | Philips MRS25        | Farnell  | MRS25-10k  |
| R4, 26.   | Resistor 100R 0.25W 1% | 100-0006     | 2   | Philips MRS25        | Farnell  | MRS25-100R |
| R5, 9,11,58,60<br>61,67,72,85,92.   | Resistor 1k0 0.25W 1%  | 100-0020     | 10  | Philips MRS25        | Farnell  | MRS25-1k0  |
| R6, 22.   | Resistor 2k2 0.25W 1%  | 100-0056     | 2   | Philips MRS25        | Farnell  | RS25-2k2   |
| R7, 17,23,24,25<br>36,40,49,50,73   | Resistor 100k 0.25W 1% | 100-0049     | 10  | Philips MRS25        | Farnell  | MRS25-100k |
| R10.  | Resistor 22k 0.25W 1%  | 100-0044     | 1   | Philips MRS25        | Farnell  | MRS25-22k  |
| R13.  | Resistor 30k 0.25W 1%  | 100-0046     | 1   | Philips MRS25        | Farnell  | MRS25-30k  |
| R15.  | Resistor 5k6 0.25W 1%  | 100-0032     | 1   | Philips MRS25        | Farnell  | MRS25-5k6  |
| R16, 57,59,62,<br>63,66,70,78.  | Resistor 1M0 0.25W 1%  | 100-0054     | 8   | Philips MRS25        | Farnell  | MRS25-1M0  |
| R18.  | Resistor 150k 0.25W 1% | 100-0050     | 1   | Philips MRS25        | Farnell  | MRS25-150k |
| R21.  | Resistor 470k 0.25W 1% | 100-0053     | 1   | Philips MRS25        | Farnell  | MRS25-470k |
| R31.  | Resistor 4k3 0.25W 1%  | 100-0029     | 1   | Philips MRS25        | Farnell  | MRS25-4k3  |
| R32.  | Resistor 6k8 0.25W 1%  | 100-0033     | 1   | Philips MRS25        | Farnell  | MRS25-6k8  |
| R34.  | Resistor 1k2 0.25W 1%  | 100-0021     | 1   | Philips MRS25        | Farnell  | MRS25-1k2  |
| R37, 42.  | Resistor 15k 0.25W 1%  | 100-0040     | 2   | Philips MRS25        | Farnell  | MRS25-15k  |
| R44, 78.  | Resistor 8k2 0.25W 1%  | 100-0036     | 2   | Philips MRS25        | Farnell  | MRS25-8k2  |
| R45, 46.  | Resistor 27k 0.25W 1%  | 100-0045     | 2   | Philips MRS25        | Farnell  | MRS25-27k  |
| R64.  | Resistor 20k 0.25W 1%  | 100-0043     | 1   | Philips MRS25        | Farnell  | MRS25-20k  |

| J115-70001  | Main PCB              |              | 1   |                  |          |               |
|---|-----------------------|--------------|-----|------------------|----------|---------------|
| ITEM  | DESCRIPTION           | JMW Part No. | QTY | Manufacturer     | Supplier | Part No.      |
| R48, 69.  | Resistor 22R 0.25W 1% | 100-0001     | 2   | Philips MRS25    | Farnell  | MRS25-22R     |
| R54.  | Resistor 3k9 0.25W 1% | 100-0028     | 1   | Philips MRS25    | Farnell  | MRS25-3k9     |
| R56.  | Resistor 7K5 0.25W 1% | 100-0035     | 1   | Philips MRS25    | Farnell  | MRS25-7K5     |
| R82, 83.  | Resistor 18k 0.25W 1% | 100-0042     | 2   | Philips MRS25    | Farnell  | MRS25-18k     |
| R84.  | Resistor 30k 0.25W 1% | 100-0046     | 1   | Philips MRS25    | Farnell  | MRS25-30K     |
| D42, 43,44,45.  | Zener 9V1             | 255-0009     | 4   | Philips          | Farnell  | BZT03 C9V1    |
| (U1)  | DIL Skt 16 way        | 357-0001     | 1   | Harwin D2816-01  | Farnell  | 178-829       |
| (U2), (U3), (U5),<br>(U6), (U8), (U8),<br>(U10).  | DIL Skt 14 way        | 357-0000     | 7   | Harwin D2814-01  | Farnell  | 178-828       |
| (U4).   | DIL Skt 40 way        | 357-0005     | 1   | Harwin D2840-01  | Farnell  | 178-839       |
| (U7).   | DIL Skt 8 way         | 357-0006     | 1   | Harwin D2808-01  | Farnell  | 178-827       |
| RN1.  | Resnet 9x10k SIL      | 106-0000     | 1   | Bourns 4610x-101 | Farnell  | 4610X-101 10k |
| C1, 2,5,7,9,11,<br>12,13,14,15,<br>16,17,21,22,<br>23,24,25,26,<br>27,28,33,34,<br>39,42,45,46,<br>47,48,49,50, | Cap Ceramic 0.1uF     | 120-0002     | 32  | Siemens          | ESD      | 035196X       |

*Thermomat Manual*

|                                       |                          |          |   |                    |         |              |
|---------------------------------------|--------------------------|----------|---|--------------------|---------|--------------|
| 51,52.                                |                          |          |   |                    |         |              |
| C4, 43.                               | Cap Ceramic 0.047uF 100V | 120-0001 | 2 | Philips CW20A 473M | Farnell | 143-734      |
| C10.                                  | Cap Ceramic 330pF        | 120-0004 | 1 | Philips 683 58331  | Farnell | 683-58331    |
| C44.                                  | Cap Polyester 0.22uF     | 121-0003 | 1 | Wima MKS2          | Farnell | 143-682      |
| D1.                                   | LED HLMP 5030            | 240-0011 | 1 | HP HLMP5030        | Farnell | HLMP5030     |
| D2.                                   | LED HLMP 5040            | 240-0002 | 1 | HP HLMP5040        | Farnell | HLMP5040     |
| D3.                                   | LED HLMP 5050            | 240-0006 | 1 | HP HLMP5050        | Farnell | HLMP5050     |
| D33, 34,35,36,<br>37,38,39,40,<br>41. | LED HLMP 6300            | 240-0012 | 9 | HP HLMP6300        | Farnell | HLMP6300-010 |
| C3, 19,8.                             | Cap Elec. 1uF 63V        | 122-0000 | 2 | Philips 035 58108  | Farnell | 107-411      |
| C6, 31,32,37,<br>38,41.               | Cap Elec. 10uF 50V       | 122-0001 | 6 | Philips 035 90008  | Farnell | 107-406      |
| C20, 29,,35,<br>36.                   | Cap Elec. 68uF 40V       | 122-0006 | 4 | Philips 035 57689  | Farnell | 107-402      |
| C30                                   | Cap Elec 1000uF 35V      | 122-000  | 1 |                    | Farnell | 286-448      |
| C40.                                  | Cap Elec. 1000uF 25V     | 122-0004 | 1 | Philips 035 56102  | Farnell | 107-394      |
| C18.                                  | Cap Elec. 1000uF 16V     | 122-0003 | 1 | Waycom WHT         | Farnell | 148-847      |
| T2, 4.                                | N-FET ZVN2106A           | 264-0001 | 2 | Zetex              | Farnell | ZVN2106A     |
| T3, 5                                 | NPN 2N3904               | 260-0001 | 2 | Farnell            |         | 2N3904       |
| U12, 15.                              | Regulator -12V 100mA     | 234-0007 | 2 | NS                 | Farnell | LM79L12ACZ   |
| U14.                                  | Regulator +12V 100mA     | 234-0002 | 1 | NS                 | Farnell | LM78L12ACZ   |
| U13.                                  | Regulator +15V 100mA     | 234-0003 | 1 | NS                 | Farnell | LM78L15ACZ   |
| D10, 31.                              | Reference 1.2V           | 256-0000 | 2 | AMS                | Farnell | AMS9491BN    |
| J1.                                   | Conn. 3 Way Skt Pcb Hdr  | 356-0134 | 1 | IMO 21.155V/3      | Farnell | 304-4683     |
| J2.                                   | Conn. SIL 6x0.1 Plug     | 356-0008 | 1 | Molex 22-27-2061   | Farnell | 143-142      |
| J3.                                   | Conn. DIP 2x18x0.1 Plug  | 356-0002 | 1 | Harwin M20-9983606 | Farnell | 148-535      |
| J4.                                   | Conn. 4 Way Skt Pcb Hdr  | 356-0135 | 1 | IMO 21.155V/4      | Farnell | 304-4695     |
| J5.                                   | Conn. 2 Way Skt Pcb Hdr  | 356-0133 | 1 | IMO 21.155V/2      | Farnell | 304-4671     |
| LK1, 2                                | Conn SIL 2x0.1 Header    | 356-0036 | 2 | Harwin M20-9993606 | Farnell | 148-533      |
| (F1), (F2).                           | Fuseholder PCB           | 300-0002 | 2 | Belling 5229       | Farnell | 146-123      |

| ITEM  | DESCRIPTION          | JMW Part No. | QTY | Manufacturer       | Supplier | Part No.  |
|---|----------------------|--------------|-----|--------------------|----------|-----------|
| J115-70001  | Main PCB             |              | 1   |                    |          |           |
| F1, F2.   | Fuse Link F1A        | 301-002      | 2   | Beswick TDS500     | Farnell  | 151-490   |
| R19.  | R Var 20k            | 105-0002     | 1   | Bourns 3296Y       | Farnell  | 348-132   |
| R12.  | R Var 10k            | 105-0000     | 1   | Bourns 3296Y       | Farnell  | 348-      |
| R33, 55,14,43.  | R Var 2k0            | 105-0001     | 4   | Bourns 3296Y       | Farnell  | 348-107   |
| R41.  | R Var 500R           | 105-0005     | 1   | Bourns 3296Y       | Farnell  | 348-089   |
| R38.  | R Var 5k0            | 105-0004     | 1   | Bourns 3296Y       | Farnell  | 348-119   |
| TP1, 2,3,4,5,6,<br>7,8,9,10,11,<br>12,13,14,15,<br>16,17,18,19,<br>20,21,22,23,<br>24,25,26,27.<br>29,30. | Test Point           | 356-0035     | 30  | William Hughes     |          | 200-201   |
| (Q1), (U11).  | TO220 Heatsink       | 309-0000     | 2   | Redpoint SW25-4    | Farnell  | 175-649   |
| (Q1), (U11).  | Clip                 | 309-0001     | 2   | Redpoint 5901      | Farnell  | 175-656   |
| Q1.   | Triac BT137-500      | 254-0005     | 1   | Philips            | Farnell  | BT137 500 |
| U11.  | Regulator 5V 1A      | 234-0004     | 1   | NS                 | Farnell  | LM7805CT  |
| U1.   | Temp Control TDA1023 | 239-0001     | 1   | Philips TDA1023/N3 | ESD      | 027397C   |
| U2.   | Dual D-type 4013     | 200-0000     | 1   | NS                 | Farnell  | CD4013BCN |
| U4.   | Display Driver/ADC   | 232-0000     | 1   | UMC                | Farnell  | UM7107A   |
| U3, 5,10.   | Quad Op-amp 324      | 231-0000     | 3   | NS                 | Farnell  | LM324N    |
| U6, 8,9.  | Quad Comp. 339.      | 230-0000     | 3   | NS                 | Farnell  | LM339N    |
| U7.   | Timer 555.           | 233-0000     | 1   | TI                 | Farnell  | TLC555CP  |
| Sounder1  | Sounder Piezo        | 336-0000     | 1   | ESD PMB24D         | ESD      | 076226G   |
| RLY1  | Relay IPCO 24V       | 331-0001     | 1   | Omron G5L 24V      | Farnell  | 178-768   |

| ITEM       | DESCRIPTION               | JMW Part No. | QTY | Manufacturer  | Supplier | Part No. |
|------------|---------------------------|--------------|-----|---------------|----------|----------|
| J115-60004 | Transformer Assembly      |              | 1   |               |          |          |
|            | Mains Transformer 12-0-12 | 131-0005     | 1   |               |          |          |
|            | Crimp Terminal 0.156      | 356-0025     | 4   | Molex         | Farnell  | 143-198  |
|            | Conn 4 way Plug Free      | 356-0132     | 1   | IMO 21.1550/4 | Farnell  | 304-4610 |
|            | Female 0.187 Faston       | 359-0020     | 2   | Davico        | RS       | 433-107  |
|            | Braided Sleeving          | 323-0024     | a/r |               |          |          |

*Thermomat Manual*

Black Shrinkable Sleeving    323-0014    a/r    Farnell    107-448

| ITEM              | DESCRIPTION                     | JMW Part No.           | QTY    | Manufacturer                          | Supplier            | Part No.   |
|-------------------|---------------------------------|------------------------|--------|---------------------------------------|---------------------|------------|
| J115-70002        | Display PCB Assembly            |                        | 1      |                                       |                     |            |
| R1, 2,3,4,5,6, 8. | Bare PCB<br>Resistor 1k0R 0.25W | J115-30002<br>100-0020 | 1<br>8 | Strathclyde Circuits<br>Philips MRS25 | Farnell             | MRS25-1k0  |
| R9.               | Resistor 680R 0.25W             | 100-0019               | 1      | Philips MRS25                         | Farnell             | MRS25-680R |
| C1, 2.            | Cap Ceramic 0.1uF               | 120-0002               | 2      | Siemens                               | ESD                 | 035196X    |
| J1.               | Conn. 2x18 0.1 Skt              | 356-0027               | 1      | Harwin                                | Farnell             | 148-538    |
| (LED1, 2,3).      | Elevated Skt Strip 15 way       | 356-0026               | 1      | Harwin                                | Farnell             | 148-531    |
| LED1, 2,3.        | 7 Segment Green LED             | 356-0031               | 2      | Samtec                                | ESS-115-TT/05       |            |
| SW1.              | 1Pole 11 Way Rotary Switch      | 241-0000               | 3      | HP HDSP560                            | Farnell             | HDSP5601   |
| SW2.              | 1PCO Push Button Switch         | 340-0000               | 1      | Lorlin RA2991                         |                     | RA2991     |
|                   |                                 | 341-0004               | 1      | C&K 8121-SH2GE                        | Phoenix Electronics | 8121       |

**14. Materials List Heating Pad**

J116- 60002 HPA 1400 (Full Table Mattress MT1400)

| Item Description          | Part No      | Qty | Manufacturer | Supplier   |
|---------------------------|--------------|-----|--------------|------------|
| Elements                  | J116 - 40004 | 4   |              |            |
| 3M Tape Type 465 2"       | 901 - 0001   | 1   | 3M           | R D Taylor |
| Thermistors Type 10K      |              | 16  | Betatherm    |            |
| Full Table Mattress Cover | J116 - 60012 | 1   | Limebank     |            |
| AXR Plug                  | 350 - 0000   | 1   | Deltron      | Farnell    |
| Wadding 2.73m             | J116 - 40007 | 1   | Limebank     |            |
| Nito Tape                 | 901 - 0000   | 1   |              |            |
| Serial No stickers        | 906 - 0005   | 1   | Farnell      |            |
| Layflat Tubing 2.5m       | 915 - 0005   | 1   | Abbotts      |            |
| 12 core grey cable 5m     | 322 - 0036   | 1   | RS           |            |
| Heatshrink 3.2m (300mm)   | 323 - 0003   | 1   | RS           |            |
| Heatshrink 5mm (300mm)    | 323 - 0004   | 1   | RS           |            |
| Heatshrink 12.7mm (300mm) | 323 - 0005   | 1   | RS           |            |
| Wire white 7/0.2mm 4m     | 322 - 0015   | 1   | RS           |            |
| Wire Grey 24/0.2mm 4m     | 322 - 0057   | 1   | RS           |            |
| Wire Red 24/0.2mm 4m      | 322 - 0058   | 1   | RS           |            |

J116- 60005 HPP900 (Half Table Mattress MH900)

| Item Description          | Part No      | Qty | Manufacturer | Supplier   |
|---------------------------|--------------|-----|--------------|------------|
| Elements                  | J116 - 40004 | 4   |              |            |
| 3M Tape type 465 2"       | 901 - 0001   | 1   | 3M           | R D Taylor |
| Thermistors Tyoe 10K      |              | 16  | Betatherm    |            |
| Half table mattress cover | J116 - 60012 | 1   | Limebank     |            |
| AXR plug                  | 350 - 0000   | 1   | Deltron      | Farnell    |
| Wadding 1.9m              | J116 - 40007 | 1   | Limebank     |            |
| Nito Tape                 | 901 - 0000   | 1   |              |            |
| Serial No stickers        | 906 - 0005   | 1   | Farnell      |            |
| Layflat tubing 1.9m       | 915 - 0005   | 1   | Abbotts      |            |
| 12 core grey cable 4.5m   | 322 - 0036   | 1   | RS           |            |
| Heatshrink 3.2mm (300mm)  | 323 - 0003   | 1   | RS           |            |
| Heatshrink 5mm (300mm)    | 323 - 0004   | 1   | RS           |            |
| Heatshrink 12.7 (300mm)   | 323 - 0006   | 1   | RS           |            |
| Wire white 7.0.2mm 3.5m   | 322 - 0015   | 1   | RS           |            |
| Wire Grey 24/0.2mm 3.5m   | 322 - 0057   | 1   | RS           |            |
| Wire Red 24/0.2mm 3.5m    | 322 - 0058   | 1   | RS           |            |

J116 - 60003 HPN400 (Neo-natal mattress MN400)

| Item Description               | Part No      | Qty | Manufacturer | Supplier   |
|--------------------------------|--------------|-----|--------------|------------|
| Elements                       | J116 - 40004 | 4   |              |            |
| 3M tape type 465 2"            | 901 - 0001   | 1   | 3M           | R D Taylor |
| Thermistors Type 10k           |              | 16  | Betatherm    |            |
| Neo-natal table mattress cover | J116 - 60012 | 1   | Limebank     |            |
| AXR Plug                       | 350 - 0000   | 1   | Deltron      | Farnell    |
| Wadding 900mm                  | J116 - 40007 | 1   | Limebank     |            |
| Nito tape                      | 901 - 0000   | 1   |              |            |
| Serial No stickers             | 906 - 0005   | 1   | Farnell      |            |
| Layflat tubing 1m              | 915 - 0005   | 1   | Abbotts      |            |
| 12 core grey cable 4m          | 322 - 0036   | 1   | RS           |            |

*Thermomat Manual*

|                           |            |   |    |
|---------------------------|------------|---|----|
| Heatshrink 3.2mm (300mm)  | 323 - 0003 | 1 | RS |
| Heatshrink 5mm (300mm)    | 323 - 0004 | 1 | RS |
| Heatshrink 12.7mm (300mm) | 323 - 0006 | 1 | RS |
| Wire white 7/0.2mm 2m     | 322 - 0015 | 1 | RS |
| Wire Grey 24/0.2mm 2m     | 322 - 0057 | 1 | RS |
| Wire Red 24/0.2mm 2m      | 322 - 0058 | 1 | RS |

14. **CIRCUIT DIAGRAMS**

BLOCK DIAGRAM  
CONTROLLER AND MATTRESS

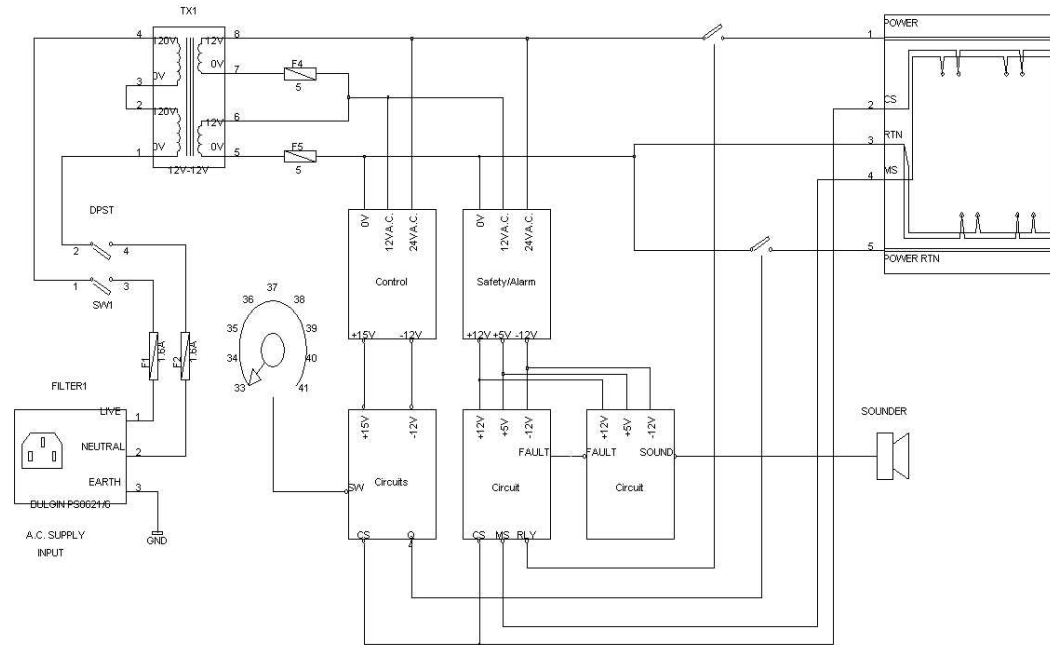

|  |                  |               |
|--|------------------|---------------|
| REV: B   | DATE: 02.02.2000 | ENG: SV       |
| REV: A   | DATE: 18.08.92   | ENG: BSA      |
| PROJECT: T5000 - DRG NO J115 - 90001   |                  |               |
| COMPANY: MVM MEDICAL LTD<br>ADDRESS: PENTLAND INDUSTRIAL ESTATE<br>CITY: LOANHEAD<br>COUNTRY: SCOTLAND |                  |               |
| INITIAL  | 27.08.92         | PAGE: 1 OF: 1 |

.J115B901.SCH



TOP LEVEL

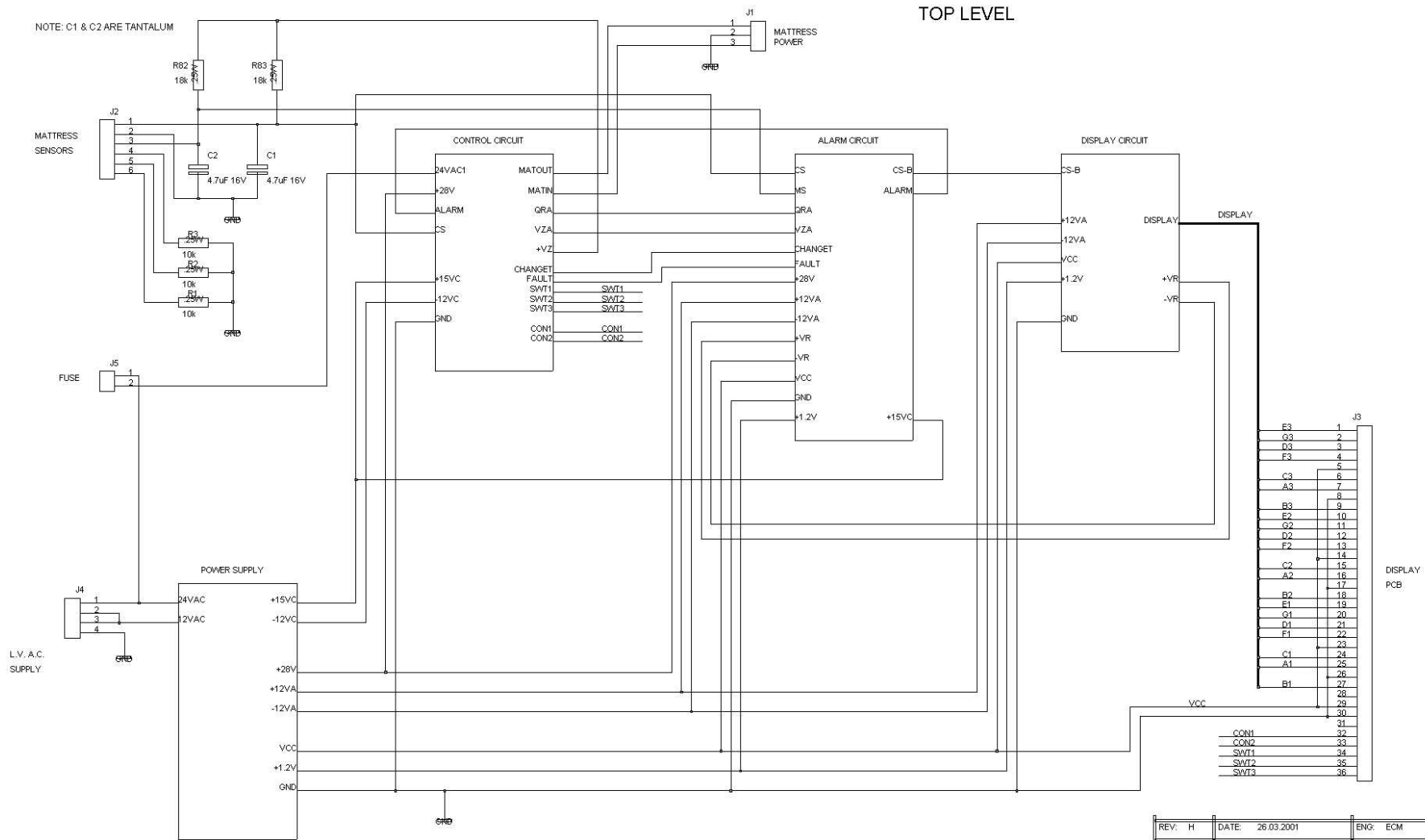

|                                     |                  |          |
|-------------------------------------|------------------|----------|
| REV: H                              | DATE: 26.03.2001 | ENG: ECM |
| DRAWING NUMBER: J115-70001          |                  |          |
| PROJECT: T5000                      |                  |          |
| COMPANY: JMW MEDICAL LTD            |                  |          |
| ADDRESS: PENTLAND INDUSTRIAL ESTATE |                  |          |
| TOWN: LOANHEAD                      |                  |          |
| COUNTRY: SCOTLAND                   |                  |          |
| INITIAL DATE: 23.01.92              | PAGE: 1          | OF: 5    |

J1157010.SCH



CONTROL CIRCUIT

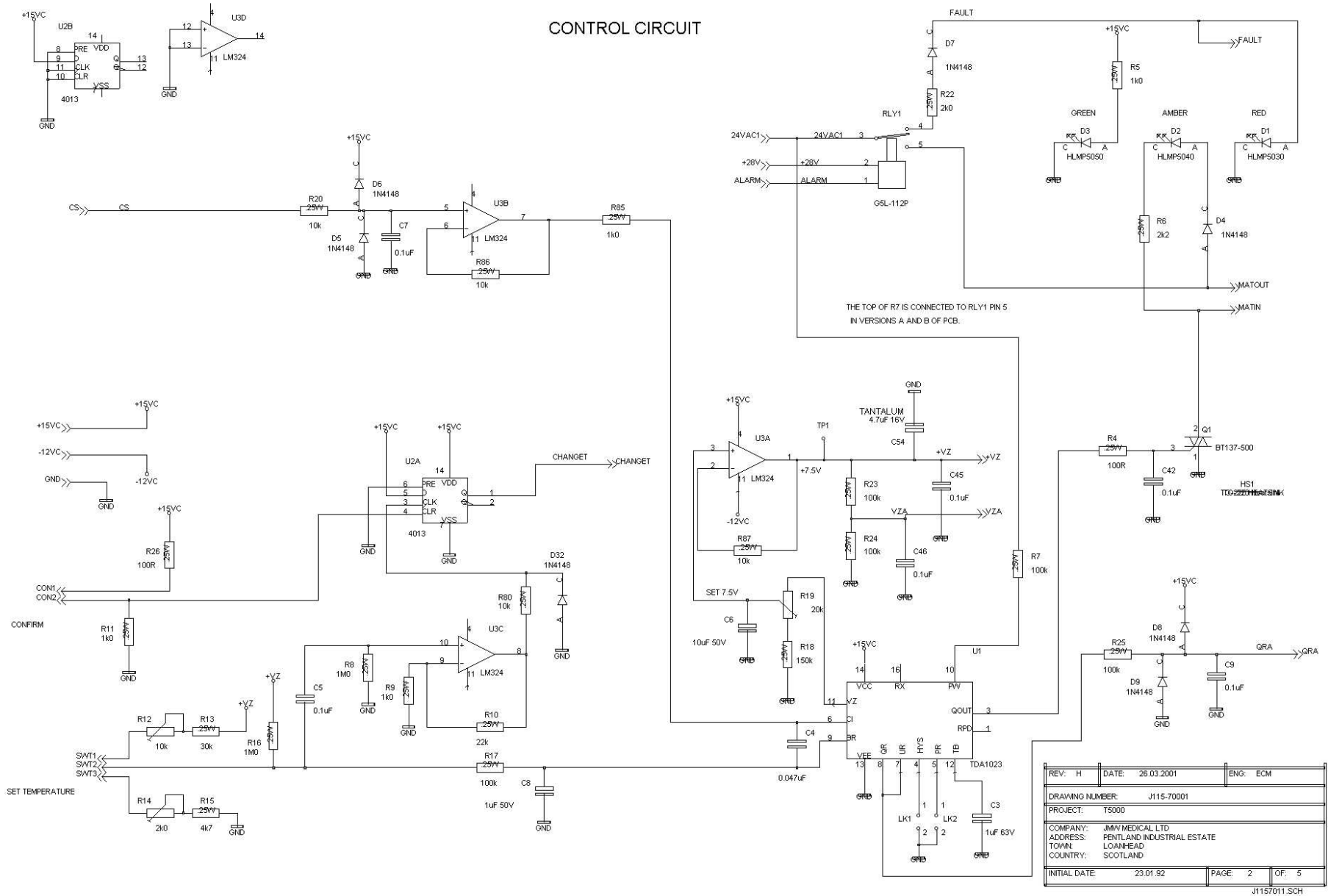

|                                     |                  |          |
|-------------------------------------|------------------|----------|
| REV: H                              | DATE: 26.03.2001 | ENG: ECM |
| DRAWING NUMBER: J115-70001          |                  |          |
| PROJECT: T5000                      |                  |          |
| COMPANY: JMW MEDICAL LTD            |                  |          |
| ADDRESS: PENTLAND INDUSTRIAL ESTATE |                  |          |
| TOWN: LOANHEAD                      |                  |          |
| COUNTRY: SCOTLAND                   |                  |          |
| INITIAL DATE: 23.01.92              | PAGE: 2          | OF: 5    |

J1157011.SCH



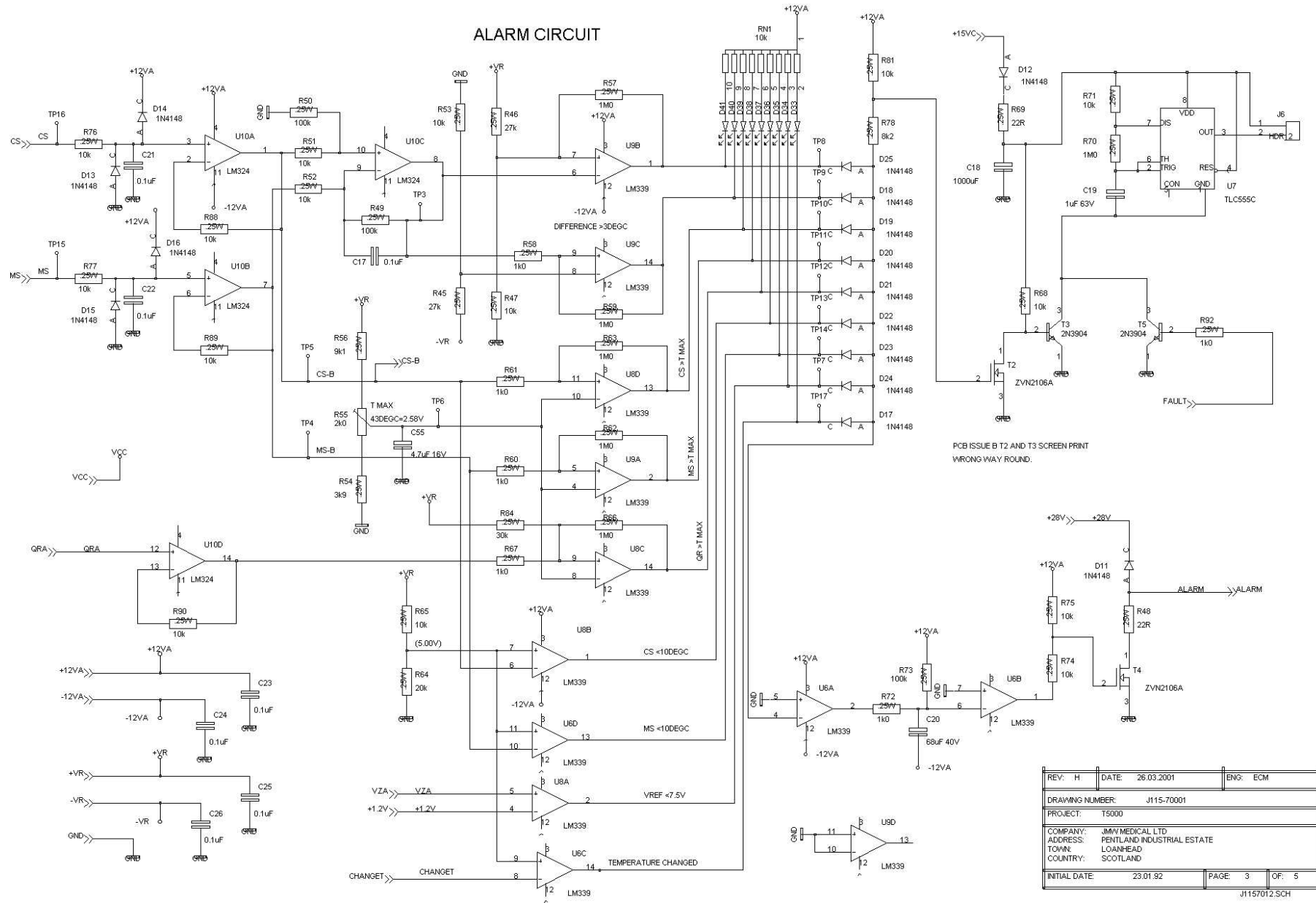



DISPLAY CIRCUIT

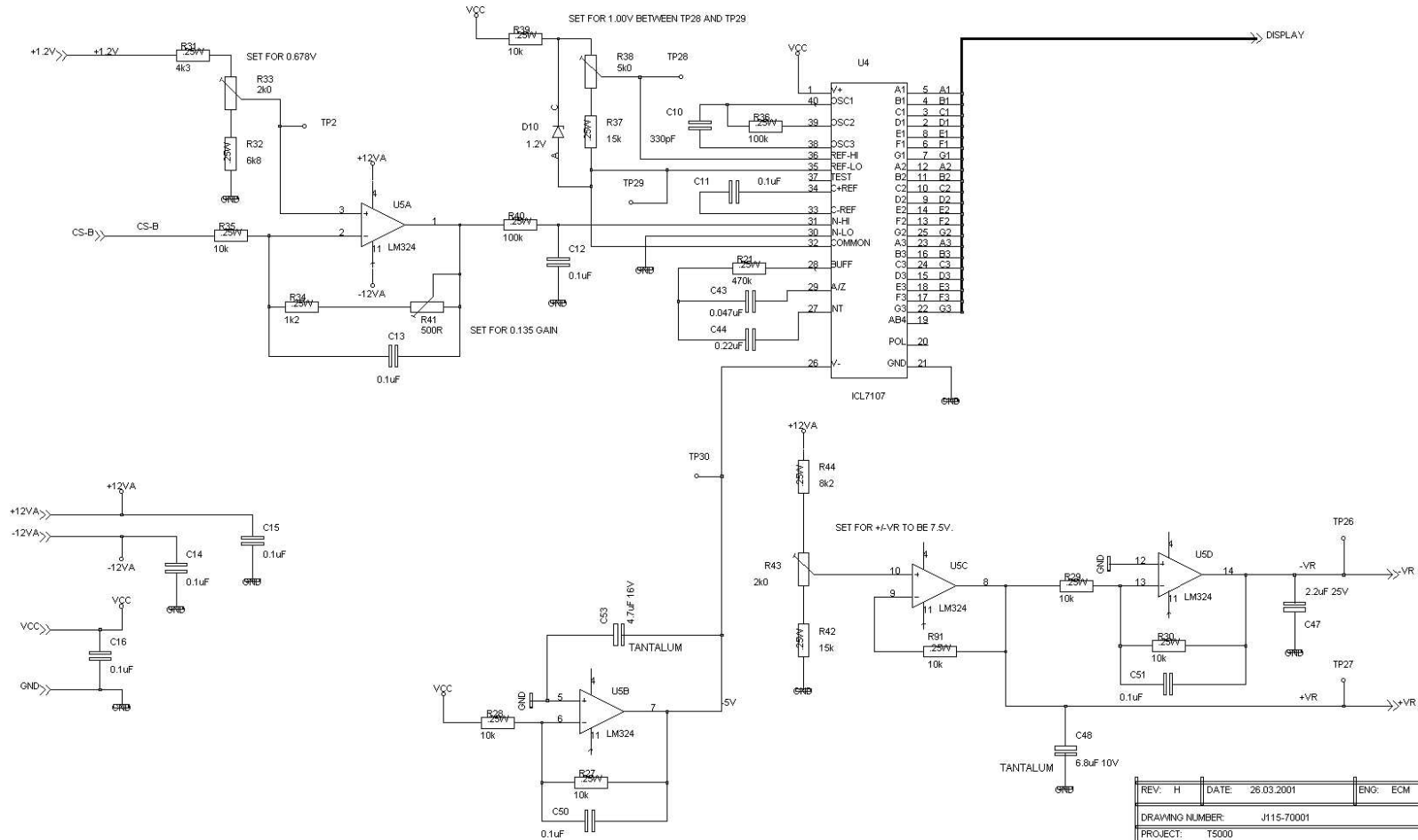



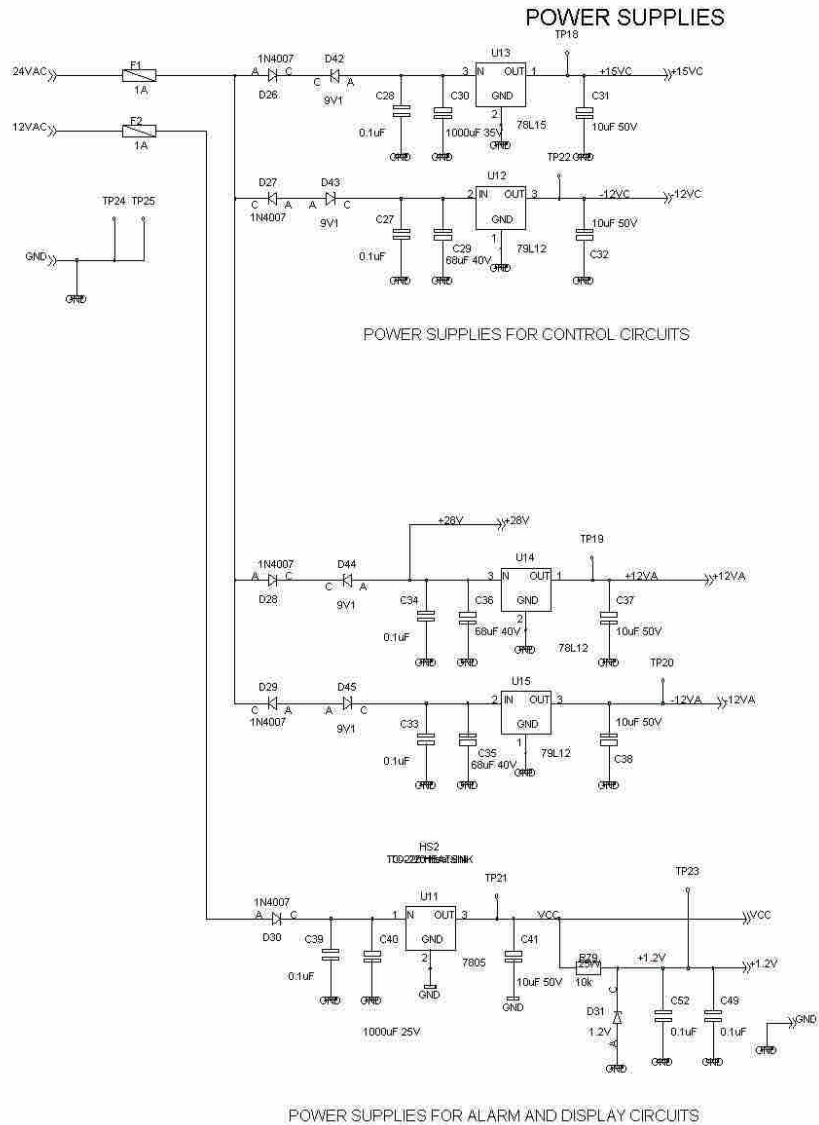

DIODES D43 AND D45 NOT FITTED IN PCB ISSUE B.

|   |                  |          |
|---|------------------|----------|
| REV: H  | DATE: 26.03.2001 | ENG: ECM |
| DRAWING NUMBER: J115-70001  |                  |          |
| PROJECT: T5000  |                  |          |
| COMPANY: JMW MEDICAL LTD<br>ADDRESS: PENTLAND INDUSTRIAL ESTATE<br>TOWN: LONMEAD<br>COUNTRY: SCOTLAND |                  |          |
| INITIAL DATE: 23.01.92  | PAGE: 5          | OF: 5    |

J1157014.SCH



DISPLAY AND SWITCH CIRCUIT



|                                     |                |          |
|-------------------------------------|----------------|----------|
| REV: B                              | DATE: 22.07.92 | ENG: BSA |
| DRAWING NUMBER: J115-70002          |                |          |
| PROJECT: T5000                      |                |          |
| COMPANY: JMW MEDICAL LTD            |                |          |
| ADDRESS: PENTLAND INDUSTRIAL ESTATE |                |          |
| TOWN: LOANHEAD                      |                |          |
| COUNTRY: SCOTLAND                   |                |          |
| INITIAL DATE: 23.01.92              | PAGE: 1        | OF: 1    |

J1157020.SCH